

# 1

CAPITOLO  
CHAPTER

## STD e StandardFLEX

## MORSE e CUBI-MORSA - VISES and VISE-TOWERS



### MORSE serie **OK** series VISES



Valigetta di campionatura  
Sample Kit case for Art.1

Art. 981

MORSE MODULARI DI PRECISIONE  
PRECISION MODULAR VISES

# MORSE e CUBI serie STANDARD

## STANDARD series VISES and CUBES

Pagg. 1.2 - 1.42

La morsa componibile **GERARDI** è costruita con il concetto di *intercambiabilità* di tutti gli elementi componenti l'attrezzatura e con la certezza di poter usare più morse sulla stessa macchina con *posizionamento ed allineamento perfetto in pochi secondi*.

Tutto ciò è possibile per l'elevato grado di precisione della morsa stessa ed in particolare per quanto riguarda: l'altezza della base, l'allineamento con tasselli di cava longitudinale rispetto alla ganascia fissa, la perpendicolarità della ganascia fissa rispetto alla base ed il parallelismo dei piani della base. Tali caratteristiche consentono di risolvere i più svariati e complicati problemi di fissaggio in pochi istanti con l'uso di più morse.

All **GERARDI** vises and accessories are modular and components of all our vises will *interchange* with perfect alignment. The vises can be matched side to side with the *highest precision and minimum of set up times* thanks to many fixed reference points.

All this is possible thanks to the high precision of the vise particularly as regards: the base high, the alignment with longitudinal key-nuts with respect to the fixed jaw, the perpendicularity of the fixed jaw with respect to the vise base and the parallelism of the base top and bottom surfaces. Those features allow us to solve the most varied and complicated problems of clamping in a few seconds with the use of more vises.

### USURA INESISTENTE

Grazie all'accurata scelta dei materiali impiegati ed allo studio dimensionale computerizzato dei componenti. **Costruzione completamente in speciali leghe di acciaio** ad alta resistenza, normalizzato, cementato e temprato con **durezza 60 ±2 HRC**. Tutto ciò al fine di conferire massima rigidità, elevate prestazioni e usura inesistente. A riprova di tutto ciò assicuriamo **5 ANNI DI GARANZIA** su tutto il programma morse e organi meccanici in genere.

### NO WEAR

Thanks to the manufacturing with only the most suitable materials and to the structure of the vise components (developed using computer customised softwares and the experience gained during many years spent working on the specific field).

High alloyed quality resistance steel, case hardened HRC 60 ±2, is used in manufacturing all the Gerardi vises and accessories in order to give maximum rigidity, high performances and no wear. As evidence we give **5 YEARS WARRANTY** on all the vises and mechanical components.

**Quattro fori filettati supplementari** e la parte posteriore di ciascuna ganascia rettificata permettono di incrementare la capacità di apertura di circa l'80% tramite il fissaggio di appositi elementi di prolunga (Art.132 e 133 da ordinare separatamente).

**4 extra tapped holes with ground back jaw rear face** increase maximum opening capacity of about 80% with the addition of jaw extensions (Art.132 and 133 to be ordered separately).

### RAPIDITA' DEI SERRAGGI

Grazie allo scorrimento del gruppo di serraggio nella guida della base (a cremagliera) fino in prossimità del pezzo da lavorare dove si adatterà automaticamente alla nicchia più vicina. L'operazione di serraggio si conclude agendo sulla vite di bloccaggio. Oltre a quello manuale meccanico, sono disponibili **4 ulteriori sistemi di serraggio intercambiabili e indipendenti**:

- 1- Idraulici
- 2- Pneumatici
- 3- Idraulici manuali
- 4- Idraulici elettrici.

L'operazione è in termini di secondi.

### QUICK CLAMPING

Thanks to the clamping device sliding in the vise base slide (compact rack type) till the proximity of the workpiece. The clamping is completed with the main screw. Besides the manual mechanic system, **4 further interchangeable and independent clamping systems are available**:

- 1- Hydraulic
  - 2- Pneumatic
  - 3- Manual hydraulic
  - 4- Electrical hydraulic.
- The change needs only few seconds.

### MODULARITÀ

Tutte le morse ed accessori sono elementi componibili, intercambiabili e perfettamente allineabili fra loro e con i quali è possibile ottenere differenti soluzioni di bloccaggio. Secondo tale principio l'unico elemento che differenzia le attrezzature con identica larghezza di presa è la base (la cui lunghezza determina la massima apertura della morsa), mentre gli altri componenti sono identici. Mediante l'aggiunta o semplice sostituzione di alcuni particolari si può variare la tipologia di bloccaggio secondo le proprie esigenze utilizzando la stessa attrezzatura acquistata in un primo momento (bloccaggi singoli, con base girevole, doppi, verticali, di pezzi piani, tondi, piatti e grezzi, manuali, idraulici o pneumatici).

### MODULARITY

All vises and accessories are modular and components of all our vises will interchange with perfect alignment to provide different workholding solutions. With this basic principle the only difference between fixtures with the same width of clamping is the base (whose length determines the maximum opening of the vise), while the rest of components have same dimensions. Through the simple addition or substitution of some particulars **You can change the type of clamping as Your needs require** using the same fixture purchased before (single clamping, swivel base, double, vertical, smooth or round or flat or rough workpieces, manual, hydraulic or pneumatic).

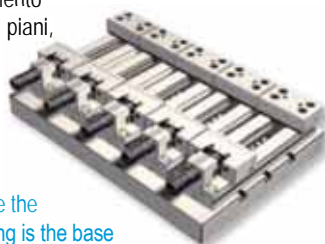

Art. 1



### DESIGN COMPATTO E MANEGGEVOLEZZA

La semplicità nonché la compattezza costruttiva consentono un'apertura notevole rispetto all'ingombro totale dell'attrezzatura. Inoltre lo stesso peso (solo 25 kg per una morsa da 150 mm di larghezza ganascia) è tale da consentire un facile trasferimento da una macchina all'altra.

### SPACE SAVING DESIGN & HANDY

The space saving design and solid construction allow a maximum blocking ratio to total overall dimension of the vise. Furthermore the weight (only 25 kg for a 150 mm jaw width vise) allows a simple moving from one machine to another.

# La morsa più diffusa (ed imitata) nel mondo ! Il trionfo perfetto: Convenienza, Qualità, Versatilità

## The most popular (and copied) vise in the world ! The perfect mix: Price, Quality, Versatility

Quattro fori filettati supplementari sopra le ganasce danno la possibilità di installare ganasce sovrapponibili per applicazioni speciali.

### VERSATILITÀ

La **ganasca fissa con gradino posteriore di 5x5 mm** consente, una volta ruotata di 180°, il perfetto accoppiamento al gradino della ganasca prismatica mobile (Art.217) ordinabile separatamente: è così possibile il serraggio di pezzi piatti senza parallele e di tondi sia in orizzontale che in verticale. Inoltre è disponibile una **vastissima gamma di ganasce** nonché un sistema di parallele piane e angolari per le più svariate applicazioni e la lavorazione di pezzi di qualsiasi forma e dimensione. **Illimitata gamma di aperture possibili.**

### VERSATILITY

4 extra tapped holes over the jaws for special Gerardi stack type jaw applications.

**Fixed jaw with 5x5 mm step** matchable to the prismatic movable jaw (Art.217 to be ordered separately) which allows to clamp plates without parallels and round workpieces vertical & horizontal way. Vertical, sideway and gang operation are possible with the appropriate components (column, narrow width jaws, etc.) **Unlimited clamping range.**

### PRECISIONI ± 0,02 mm

Slittone base con tutte le superfici di scorrimento ed accoppiamento rettificate. L'allineamento agli assi della macchina avviene grazie alle **chiavette longitudinali e trasversali (16H7)** o fori di posizionamento (Ø16 mm F7), a richiesta, previsti sulla base di ciascuna morsa. Naturalmente tutto ciò consente oltre alle precisioni dichiarate **tempi di installazione ristrettissimi.**

### HIGHEST ACCURACIES ± 0,02 mm

Solid vise base. Every sliding and coupling surface is ground. **Centesimal tolerances** are guaranteed by checking cycles with CNC measuring machine. The perfect alignment with the machine axis is given by **longitudinal and cross keyways (16H7)** or positioning holes (Ø16 mm F7), upon specific request, on the vise base. Of course this allows **minimum of set up times and gang operations.**

### RIGIDITA' & SICUREZZA

Entrambe le ganasce sono costruite in corpo unico (non esistono slitte o tasselli di fissaggio) per garantire una maggiore rigidità e nessuna flessione.

Entrambe le piastre ganasce sono costruite con **un angolo di spinta verso il basso.** Ciò assicura, nel momento della chiusura, una trazione del pezzo contro la base della morsa (per trascinarsi) e, di conseguenza, un bloccaggio sicuro e preciso.

### RIGIDITY & SAFETY

**Both jaws bodies are built in one solid piece** (no slides or key-nuts): in order to guarantee higher rigidity & no bendings.

Both jaw plates are manufactured with **a pull down angle.** This ensure, during the clamping operation, a downward run of the workpiece against the vise base (by dragging) and thus a precise and safety clamping.







1

Tipo (grandezza) morsa / Vise (type) size	kN	1		2		3		4	
		16 kN	25 kN	30 kN	30 kN	30 kN	30 kN	30 kN	
Apertura massima / Maximum spread	A	100	150	200	300	200	300	400	500
	W	100	125	150				175	
	B	30	40	50				60	
	C	35	40	50				58	
	D	270	345	420	520	455	555	655	755
	G	75	95	125				145	
	kg	6.8	12.9	25.5	29	37	42	47	52
	Cod.	3.01.00000	3.02.10000	3.03.20000	3.03.30000	3.04.20000	3.04.30000	3.04.40000	3.04.50000

**Art. 1**

Morsa modulare di precisione STD con ganascia mobile monoblocco guidata

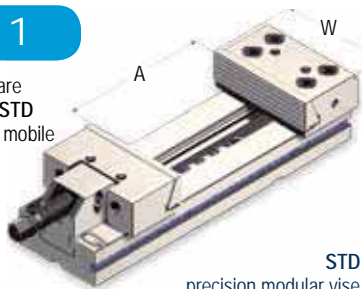

STD precision modular vise with solid guided movable jaw

**AMPLIA LE TUE APPLICAZIONI TRAMITE GLI ACCESSORI MODULARI !**

**Art. 313**

Piastre magnetiche parallele piane  
Magnetic parallel plates

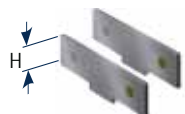

Cod.	4.31.31000	4.31.32000	4.31.33000	4.31.34000
H	23	33	43	53

**Art. 212**

Ganascia mobile intermedia (da usare con Art. 313)  
Intermediate movable jaw (to be used with Art. 313)

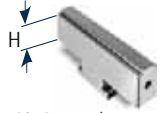

Cod.	1.21.21000	1.21.22000	1.21.23000	1.21.24000
H				

**Art. 217**

Ganascia mobile prismatica  
Prismatic movable jaw



Cod.	2.21.71000	2.21.72000	2.21.73000	2.21.74000
H				

**Art. 271**

Supporto di serraggio con cilindro idraulico  
Clamping support with hydraulic cylinder



Cod.	2.27.11000	2.27.12000	2.27.13000	2.27.14000
H				

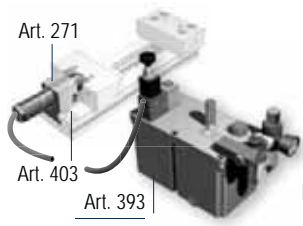

**Art. 391**

CNC / CNC

**Art. 392**

Pneumatico / Air control

Cod.	4.39.11000	4.39.12000	4.39.13000	4.39.14000
H				
Cod.	4.39.21000	4.39.22000	4.39.23000	4.39.24000
H				

Servocomandi oleopneumatici (completi di 1 cilindro e supporto) per serraggi multipli *contemporanei* o *indipendenti*, da 2 a 6 morse. Vedi pagg. 4.32, 4.33, 4.34

**Dotazione standard:**

- 1 arresto laterale Art. 370
- 1 coppia di tasselli di posizionamento Art. 297 (Standard per cava da 16 mm; altre dimensioni a richiesta senza variazione di prezzo)
- 1 chiave a pipa Art. 375 ■ 1 chiave a "T" Art. 376

Extra per ogni foro calibrato (tolleranza F7):

**Art. 1**

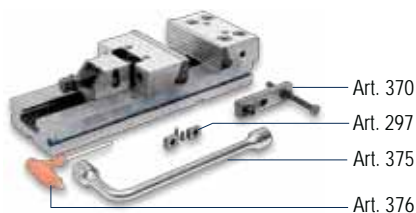

**Standard equipment:**

- 1 workstop Art. 370
- 1 pair of positioning key-nuts Art. 297 (Standard for 16 mm slot. Other dimensions available on request without price change)
- 1 box wrench Art. 375 ■ 1 T-wrench Art. 376

Extra charge for each ground hole (F7 tolerance):

**Art. 1**

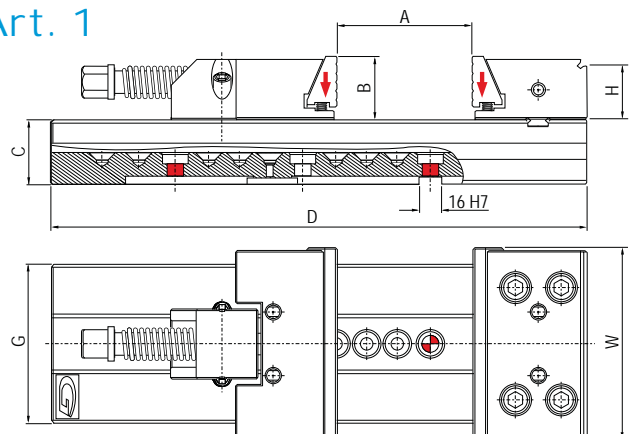

Vedi gruppo 4 per gamma completa accessori  
See group 4 for complete range of accessories

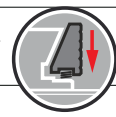

5 40 kN					6 40 kN						
200	300	400	500	600	200	300	400	500	600	700	800
200					300						
65					80						
70					78						
495	595	695	795	895	535	635	735	835	935	1035	1135
170					195						
64	69	74	79	84	95	105	115	125	135	145	155
3.05.20000	3.05.30000	3.05.40000	3.05.50000	3.05.60000	3.06.20000	3.06.30000	3.06.40000	3.06.50000	3.06.60000	3.06.70000	3.06.80000

**UPGRADE YOUR VISE APPLICATIONS THROUGH MODULAR ACCESSORIES !**

4.31.35000		4.31.36000
<b>Art. 313</b>		
53		68
1.21.25000		1.21.26000
<b>Art. 212</b>		
2.21.75000		2.21.76000
<b>Art. 217</b>		
2.27.15000		2.27.16000
<b>Art. 271</b>		
4.39.15000		4.39.16000
<b>Art. 391</b>		
4.39.25000		4.39.26000
<b>Art. 392</b>		

Pneumo-hydraulic servo units (complete of hydraulic cylinder + support) for multiple clamping *simultaneous* or *independent*, from 2 to 6 vises. See *pagg. 4.32, 4.33, 4.34*

**Art. 1**

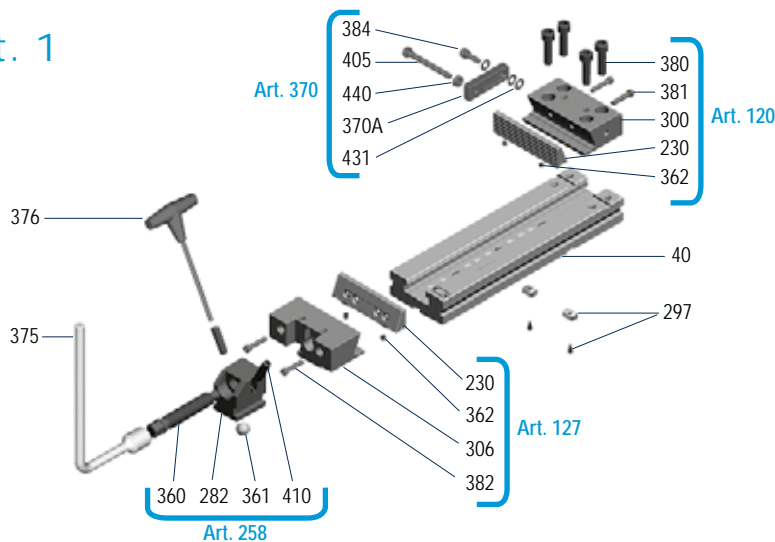

Art.	Pag.	Art.	Pag.
40	1.20	376	4.27
230	4.7	380	4.20
282	4.28	381	4.20
297	4.27	382	4.20
300	4.21	384	4.20
306	4.21	405	4.27
360	4.28	410	4.28
361	4.28	431	4.20
362	4.20	440	4.20
370A	4.27	-	-
375	4.27	-	-



1

Tipo (grandezza) morsa / Vise (type) size		1		2		3		4		
		kN	16 kN	25 kN	30 kN		30 kN			
Apertura massima / Maximum spread		A	100	150	200	300	200	300	400	500
<b>Art. 1Z</b>		W	100	125	150		175			
Morsa STD con ganascia mobile monoblocco guidata per Zero Point		B	30	40	50		60			
		C	35	40	50		58			
STD vise with guided solid movable jaw for Zero Point System		D	270	345	420	520	455	555	655	755
		G	75	95	125		145			
		kg	7.3	13.2	26.2	29.7	37.9	43	48.1	53.2
		Cod.	1.1Z.10000	1.1Z.20000	1.1Z.32000	1.1Z.33000	1.1Z.42000	1.1Z.43000	1.1Z.44000	1.1Z.45000

**AMPLIA LE TUE APPLICAZIONI TRAMITE GLI ACCESSORI MODULARI !**

**Art. 313**  
Piastre magnetiche parallele piane  
Magnetic parallel plates

Cod.	4.31.31000	4.31.32000	4.31.33000	4.31.34000
H	23	33	43	53

**Art. 212**  
Ganascia mobile intermedia  
(da usare con Art. 313)  
Intermediate movable jaw (to be used with Art. 313)

Cod.	1.21.21000	1.21.22000	1.21.23000	1.21.24000
------	------------	------------	------------	------------

**Art. 217**  
Ganascia mobile prismatica  
Prismatic movable jaw

Cod.	2.21.71000	2.21.72000	2.21.73000	2.21.74000
------	------------	------------	------------	------------

**Art. 271**  
Supporto di serraggio con cilindro idraulico  
Clamping support with hydraulic cylinder

Cod.	2.27.11000	2.27.12000	2.27.13000	2.27.14000
------	------------	------------	------------	------------

**Art. 391**  
CNC / CNC

**Art. 392**  
Pneumatico / Air control

Cod.	4.39.11000	4.39.12000	4.39.13000	4.39.14000
Cod.	4.39.21000	4.39.22000	4.39.23000	4.39.24000

Servocomandi oleopneumatici (completi di 1 cilindro e supporto) per serraggi multipli *contemporanei* o *indipendenti*, da 2 a 6 morse. Vedi pagg. 4.32, 4.33, 4.34

- Dotazione standard:
- 1 arresto laterale Art. 370
  - 2 tiranti Art. 10A
  - 1 chiave a pipa Art. 375
  - 1 chiave a "T" Art. 376



- Standard equipment:
- 1 workstop Art. 370
  - 2 pullstuds Art. 10A
  - 1 box wrench Art. 375
  - 1 T-wrench Art. 376

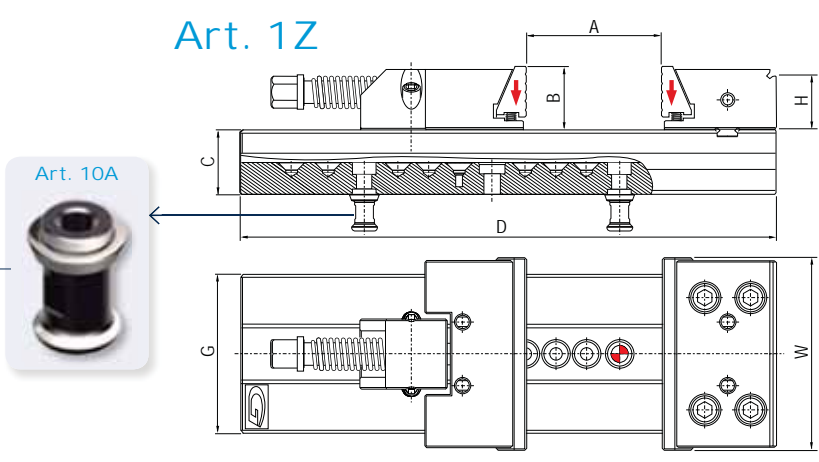

Vedi gruppo 4 per gamma completa accessori  
See group 4 for complete range of accessories



5 40 kN					6 40 kN						
200	300	400	500	600	200	300	400	500	600	700	800
200					300						
65					80						
70					78						
495	595	695	795	895	535	635	735	835	935	1035	1135
170					195						
65.3	70.3	75.3	80.3	85.3	97	107	117	127	137	147	157
1.1Z.52000	1.1Z.53000	1.1Z.54000	1.1Z.55000	1.1Z.56000	1.1Z.62000	1.1Z.63000	1.1Z.64000	1.1Z.65000	1.1Z.66000	1.1Z.67000	1.1Z.68000

**UPGRADE YOUR VISE APPLICATIONS THROUGH MODULAR ACCESSORIES !**

4.31.35000		4.31.36000
<b>Art. 313</b>		
53		68
1.21.25000		1.21.26000
<b>Art. 212</b>		
2.21.75000		2.21.76000
<b>Art. 217</b>		
2.27.15000		2.27.16000
<b>Art. 271</b>		
4.39.15000		4.39.16000
<b>Art. 391</b>		
4.39.25000		4.39.26000
<b>Art. 392</b>		

Pneumo-hydraulic servo units (complete of hydraulic cylinder + support) for multiple clamping *simultaneous* or *independent*, from 2 to 6 vises. See pagg. 4.32, 4.33, 4.34

**Art. 1Z**

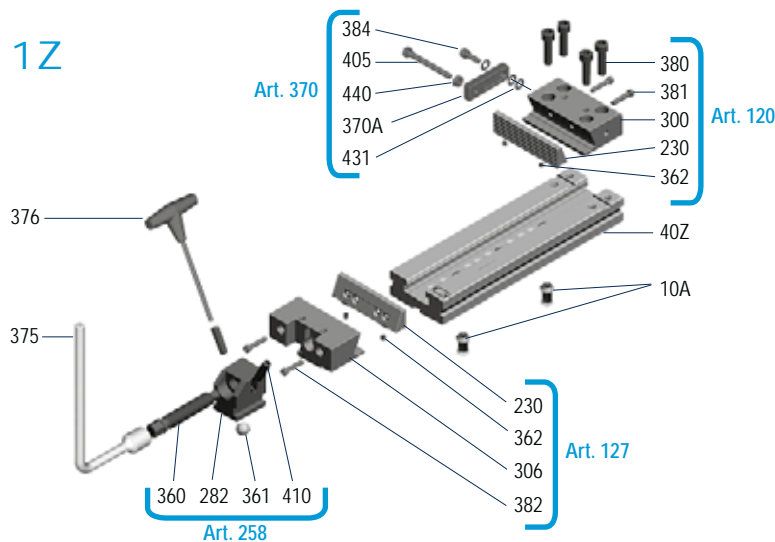

Art.	Pag.	Art.	Pag.
10A	9.25	376	4.27
40Z	1.20	380	4.20
230	4.7	381	4.20
282	4.28	382	4.20
300	4.21	384	4.20
306	4.21	405	4.27
360	4.28	410	4.28
361	4.28	431	4.20
362	4.20	440	4.20
370A	4.27	-	-
375	4.27	-	-

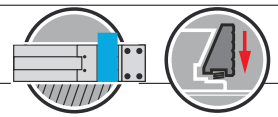

Tipo (grandezza) morsa / Vise (type) size	kN	1		2		3		4	
		16 kN	25 kN	30 kN		30 kN			
Apertura massima / Maximum spread	A	100	150	200	300	200	300	400	500
Art. 12	W	75	95	125		145			
	B	30	40	50		60			
Morsa STD con ganasce ridotte rettificate	C	35	40	50		58			
	D	270	345	420	520	455	555	655	755
	G	75	95	125		145			
	kg	6.2	11.9	24.2	27.8	35	39	46	51
	Cod.	3.01.00120	3.02.10120	3.03.20120	3.03.30120	3.04.20120	3.04.30120	3.04.40120	3.04.50120

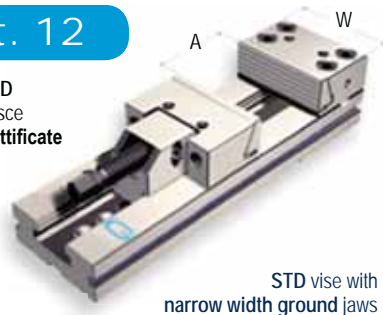

STD vise with narrow width ground jaws

**AMPLIA LE TUE APPLICAZIONI TRAMITE GLI ACCESSORI MODULARI !**

**Art. 313R**  
Piastrine magnetiche parallele piane  
Magnetic parallel plates

Cod.	4.31.3R100	4.31.3R200	4.31.3R300	4.31.3R400
H	23	33	43	53

**Art. 213**  
Ganascia mobile intermedia  
(da usare con Art. 313R)  
Intermediate movable jaw (to be used with Art. 313R)

Cod.	1.21.31000	1.21.32000	1.21.33000	1.21.34000
H				

**Art. 218**  
Ganascia mobile prismatica  
Prismatic movable jaw

Cod.	2.21.81000	2.21.82000	2.21.83000	2.21.84000

**Art. 271**  
Supporto di serraggio con cilindro idraulico  
Clamping support with hydraulic cylinder

Cod.	2.27.11000	2.27.12000	2.27.13000	2.27.14000

**Art. 391**  
CNC / CNC

**Art. 392**  
Pneumatico / Air control

Cod.	4.39.11000	4.39.12000	4.39.13000	4.39.14000
Cod.	4.39.21000	4.39.22000	4.39.23000	4.39.24000

Servocomandi oleopneumatici (completi di 1 cilindro e supporto) per serraggi multipli *contemporanei* o *indipendenti*, da 2 a 6 morse. *Vedi pagg. 4.32, 4.33, 4.34*

- Dotazione standard:**
- 1 arresto laterale Art. 370
  - 1 coppia di tasselli di posizionamento Art. 297 (Standard per cava da 16 mm; altre dimensioni a richiesta senza variazione di prezzo)
  - 1 chiave a pipa Art. 375 ■ 1 chiave a "T" Art. 376
- Extra per ogni foro calibrato (tolleranza F7):

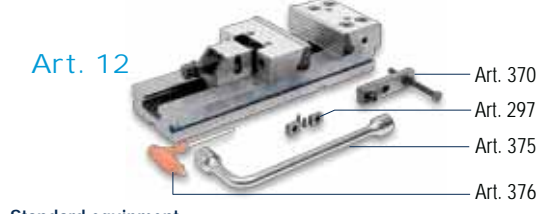

- Standard equipment:**
- 1 workstop Art. 370
  - 1 pair of positioning key-nuts Art. 297 (Standard for 16 mm slot. Other dimensions available on request without price change)
  - 1 box wrench Art. 375 ■ 1 T-wrench Art. 376
- Extra charge for each ground hole (F7 tolerance):

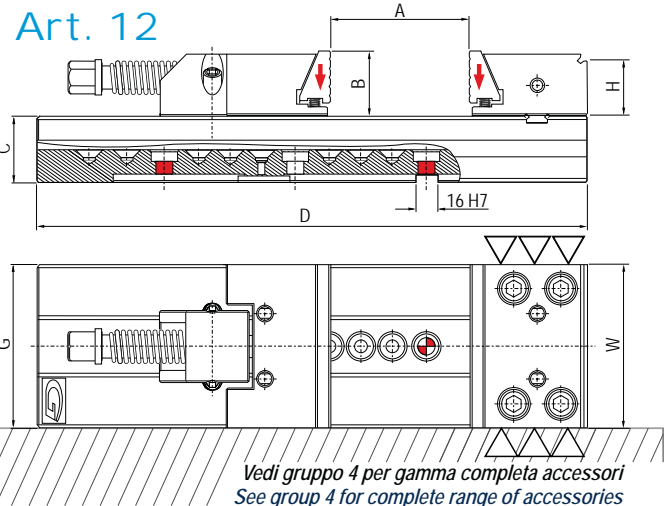



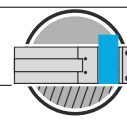

5 40 kN					6 40 kN						
200	300	400	500	600	200	300	400	500	600	700	800
		170						195			
		65						80			
		70						78			
495	595	695	795	895	535	635	735	835	935	1035	1135
		170						195			
62	67	72	77	82	88	98	108	118	128	138	148
3.05.20120	3.05.30120	3.05.40120	3.05.50120	3.05.60120	3.06.20120	3.06.30120	3.06.40120	3.06.50120	3.06.60120	3.06.70120	3.06.80120

**UPGRADE YOUR VISE APPLICATIONS THROUGH MODULAR ACCESSORIES !**

4.31.3R500		4.31.3R600
<b>Art. 313R</b>		
53		68

1.21.35000		1.21.36000
<b>Art. 213</b>		

2.21.85000		2.21.86000
<b>Art. 218</b>		

2.27.15000		2.27.16000
<b>Art. 271</b>		

4.39.15000		4.39.16000
<b>Art. 391</b>		

4.39.25000		4.39.26000
<b>Art. 392</b>		

Pneumo-hydraulic servo units (complete of hydraulic cylinder + support) for multiple clamping simultaneous or independent, from 2 to 6 vises. *See pagg. 4.32, 4.33, 4.34*

**Art. 12**

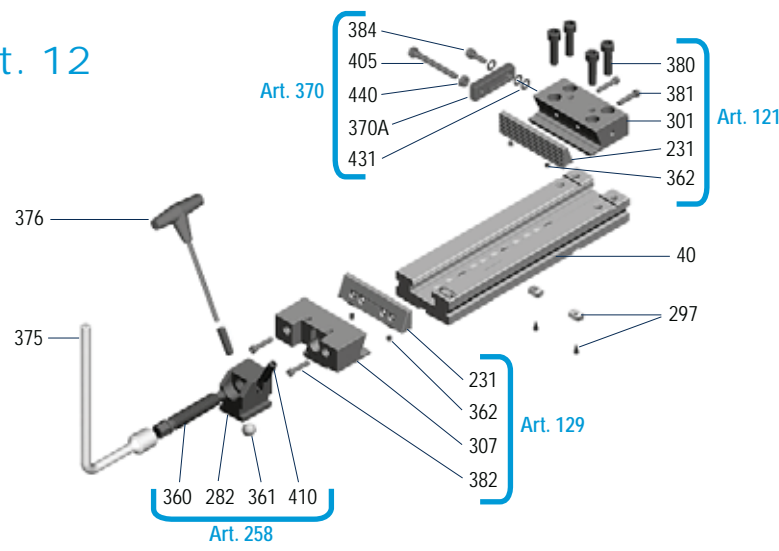

Art.	Pag.	Art.	Pag.
40	1.20	375	4.27
231	4.7	376	4.27
282	4.28	380	4.20
297	4.27	381	4.20
301	4.21	382	4.20
307	4.21	384	4.20
360	4.28	405	4.27
361	4.28	410	4.28
362	4.20	431	4.20
370A	4.27	440	4.20

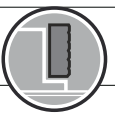

1

Tipo (grandezza) morsa / Vise (type) size	kN	1		2		3		4	
		16 kN	25 kN	30 kN		30 kN			
Apertura massima / Maximum spread	A	100	150	200	300	200	300	400	500
	W	100	125	150		175			
	B	30	40	50		60			
	C	35	40	50		58			
	D	270	345	420	520	455	555	655	755
	G	75	95	125		145			
	kg	6.8	12.9	25.5	29	37	42	47	52
	Cod.	1.14.10000	1.14.20000	1.14.32000	1.14.33000	1.14.42000	1.14.43000	1.14.44000	1.14.45000

**Art. 14**

Morsa STD con ganasce a piastre piane

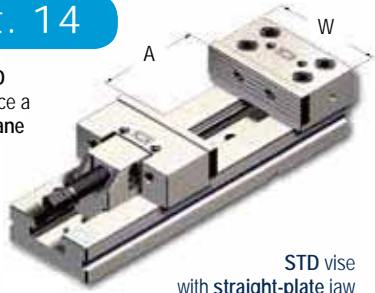

STD vise with straight-plate jaw



**AMPLIA LE TUE APPLICAZIONI TRAMITE GLI ACCESSORI MODULARI !**

**Art. 313**

Piastre magnetiche parallele piane  
Magnetic parallel plates

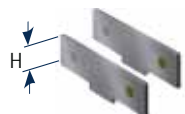

Cod.	4.31.31000	4.31.32000	4.31.33000	4.31.34000
H	23	33	43	53

**Art. 212**

Ganasce mobile intermedia (da usare con Art.313)  
Intermediate movable jaw (to be used with Art.313)



Cod.	1.21.21000	1.21.22000	1.21.23000	1.21.24000
------	------------	------------	------------	------------

**Art. 246**

Piastra piana in acciaio lavorabile  
Machinable steel straight jaw plate



Cod.	1.24.61000	1.24.62000	1.24.63000	1.24.64000
------	------------	------------	------------	------------

**Art. 271**

Supporto di serraggio con cilindro idraulico  
Clamping support with hydraulic cylinder



Cod.	2.27.11000	2.27.12000	2.27.13000	2.27.14000
------	------------	------------	------------	------------

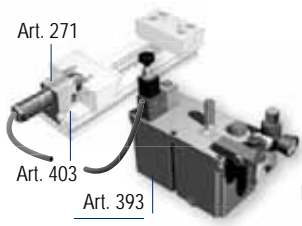

**Art. 391**

CNC / CNC

**Art. 392**

Pneumatico / Air control

Cod.	4.39.11000	4.39.12000	4.39.13000	4.39.14000
Cod.	4.39.21000	4.39.22000	4.39.23000	4.39.24000

Servocomandi oleopneumatici (completi di 1 cilindro e supporto) per serraggi multipli *contemporanei* o *indipendenti*, da 2 a 6 morse. Vedi pagg. 4.32, 4.33, 4.34

**Dotazione standard:**

- 1 arresto laterale Art. 370
- 1 coppia di tasselli di posizionamento Art. 297 (Standard per cava da 16 mm; altre dimensioni a richiesta senza variazione di prezzo)
- 1 chiave a pipa Art. 375 ■ 1 chiave a "T" Art. 376

Extra per ogni foro calibrato (tolleranza F7):

**Art. 14**

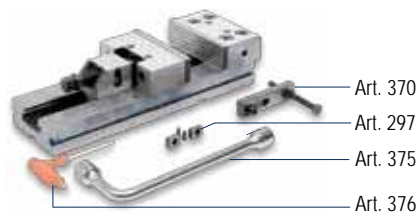

**Standard equipment:**

- 1 workstop Art. 370
- 1 pair of positioning key-nuts Art. 297 (Standard for 16 mm slot. Other dimensions available on request without price change)
- 1 box wrench Art. 375 ■ 1 T-wrench Art. 376

Extra charge for each ground hole (F7 tolerance):

**Art. 14**

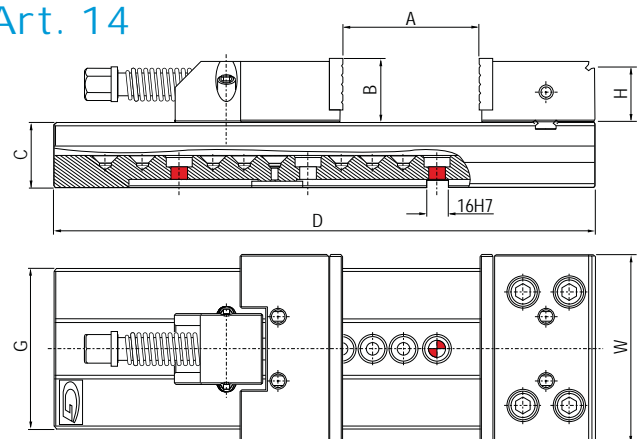

Vedi gruppo 4 per gamma completa accessori  
See group 4 for complete range of accessories



5 40 kN					6 40 kN						
200	300	400	500	600	200	300	400	500	600	700	800
200					300						
65					80						
70					78						
495	595	695	795	895	535	635	735	835	935	1035	1135
170					195						
64	69	74	79	84	95	105	115	125	135	145	155
1.14.52000	1.14.53000	1.14.54000	1.14.55000	1.14.56000	1.14.62000	1.14.63000	1.14.64000	1.14.65000	1.14.66000	1.14.67000	1.14.68000

**UPGRADE YOUR VISE APPLICATIONS THROUGH MODULAR ACCESSORIES !**

4.31.35000		4.31.36000
<b>Art. 313</b>		
53		68
1.21.25000		1.21.26000
<b>Art. 212</b>		
1.24.65000		1.24.66000
<b>Art. 246</b>		
2.27.15000		2.27.16000
<b>Art. 271</b>		
4.39.15000		4.39.16000
<b>Art. 391</b>		
4.39.25000		4.39.26000
<b>Art. 392</b>		

Pneumo-hydraulic servo units (complete of hydraulic cylinder + support) for multiple clamping simultaneous or independent, from 2 to 6 vises. *See pagg. 4.32, 4.33, 4.34*

**Art. 14**

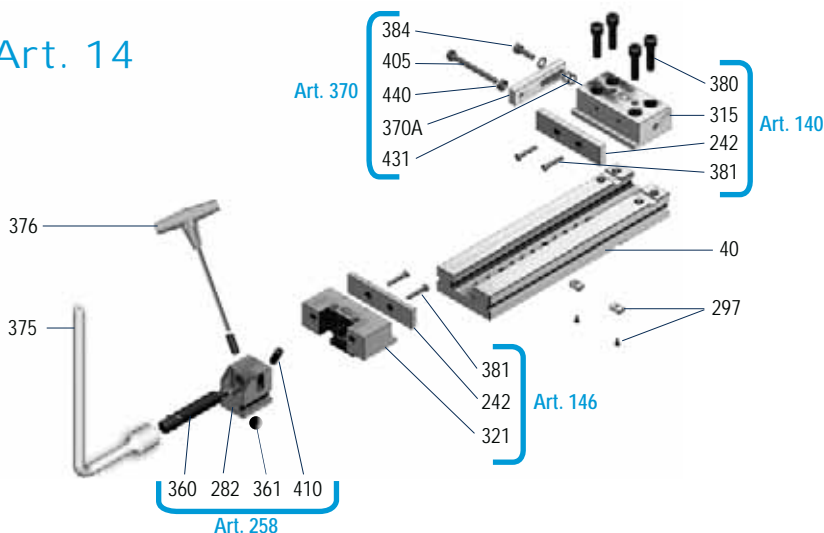

Art.	Pag.	Art.	Pag.
40	1.20	380	4.18
242	4.9	381	4.18
282	4.28	384	4.18
297	4.27	405	4.25
315	4.22	410	4.26
321	4.22	431	4.18
360	4.28	440	4.18
361	4.28	-	-
370A	4.27	-	-
375	4.27	-	-
376	4.28	-	-

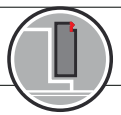

Tipo (grandezza) morsa / Vise (type) size	kN	1		2		3		4	
		16 kN	25 kN	30 kN	30 kN	30 kN	30 kN	30 kN	30 kN
Apertura massima / Maximum spread	A	100	150	200	300	200	300	400	500
	W	75	95	125		145			
	B	30	40	50		60			
	C	35	40	50		58			
	D	270	345	420	520	455	555	655	755
	G	75	95	125		145			
	kg	6.2	11.9	24.2	27.8	35	39	46	51
	Cod.	1.15.10000	1.15.20000	1.15.32000	1.15.33000	1.15.42000	1.15.43000	1.15.44000	1.15.45000

**Art. 15**

Morsa STD con piastre ganasce GRIP a forte serraggio, (ridotte rettificate)

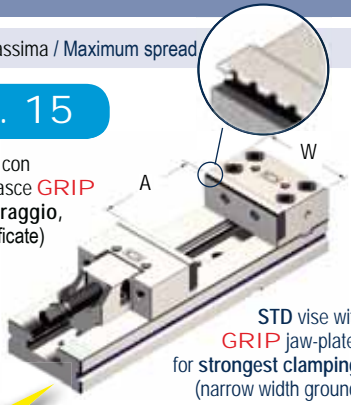

STD vise with GRIP jaw-plates for strongest clamping, (narrow width ground)

**AMPLIA LE TUE APPLICAZIONI TRAMITE GLI ACCESSORI MODULARI !**

**Art. 313R**

Piastre magnetiche parallele piane  
 Magnetic parallel plates

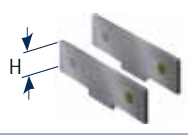

Cod.	4.31.3R100	4.31.3R200	4.31.3R300	4.31.3R400
H	23	33	43	53

**Art. 247**

Piastra piana ridotta in acciaio lavorabile  
 Machinable steel narrow width straight jaw plate



Cod.	1.24.71000	1.24.72000	1.24.73000	1.24.74000
------	------------	------------	------------	------------

**Art. 218**

Ganascia mobile prismatica  
 Prismatic movable jaw



Cod.	2.21.81000	2.21.82000	2.21.83000	2.21.84000
------	------------	------------	------------	------------

**Art. 271**

Supporto di serraggio con cilindro idraulico  
 Clamping support with hydraulic cylinder



Cod.	2.27.11000	2.27.12000	2.27.13000	2.27.14000
------	------------	------------	------------	------------

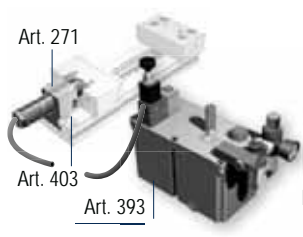

**Art. 391**  
 CNC / CNC

**Art. 392**  
 Pneumatico / Air control

Cod.	4.39.11000	4.39.12000	4.39.13000	4.39.14000
Cod.	4.39.21000	4.39.22000	4.39.23000	4.39.24000

Servocomandi oleopneumatici (completi di 1 cilindro e supporto) per serraggi multipli *contemporanei* o *indipendenti*, da 2 a 6 morse. Vedi pagg. 4.32, 4.33, 4.34

**Dotazione standard:**

- 1 arresto laterale Art. 370
  - 1 coppia di tasselli di posizionamento Art. 297 (Standard per cava da 16 mm; altre dimensioni a richiesta senza variazione di prezzo)
  - 1 chiave a pipa Art. 375 ■ 1 chiave a "T" Art. 376
- Extra per ogni foro calibrato (tolleranza F7):

**Art. 15**

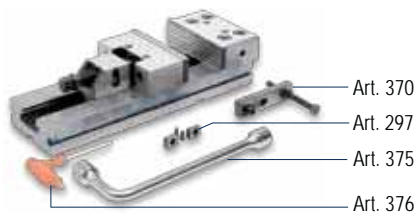

**Standard equipment:**

- 1 workstop Art. 370
  - 1 pair of positioning key-nuts Art. 297 (Standard for 16 mm slot. Other dimensions available on request without price change)
  - 1 box wrench Art. 375 ■ 1 T-wrench Art. 376
- Extra charge for each ground hole (F7 tolerance):

**Art. 15**

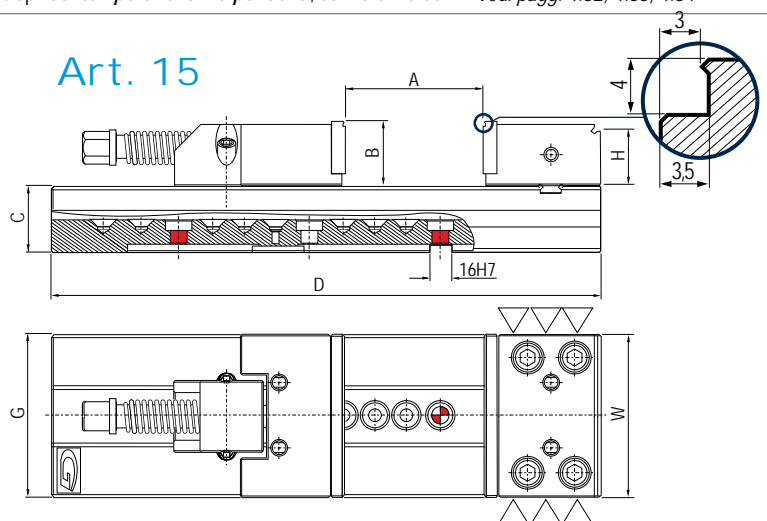

Vedi gruppo 4 per gamma completa accessori - See group 4 for complete range of accessories



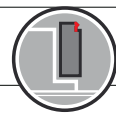

5 40 kN					6 40 kN						
200	300	400	500	600	200	300	400	500	600	700	800
170					195						
65					80						
70					78						
495	595	695	795	895	535	635	735	835	935	1035	1135
170					195						
62	67	72	77	82	88	98	108	118	128	138	148
1.15.52000	1.15.53000	1.15.54000	1.15.55000	1.15.56000	1.15.62000	1.15.63000	1.15.64000	1.15.65000	1.15.66000	1.15.67000	1.15.68000

**UPGRADE YOUR VISE APPLICATIONS THROUGH MODULAR ACCESSORIES !**

4.31.3R500		4.31.3R600
Art. 313R		
53		68
1.24.75000		1.24.76000
Art. 247		
2.21.85000		2.21.86000
Art. 218		
2.27.15000		2.27.16000
Art. 271		
4.39.15000		4.39.16000
Art. 391		
4.39.25000		4.39.26000
Art. 392		

Pneumo-hydraulic servo units (complete of hydraulic cylinder + support) for multiple clamping simultaneous or independent, from 2 to 6 vises. *See pagg. 4.32, 4.33, 4.34*

**Art. 15**

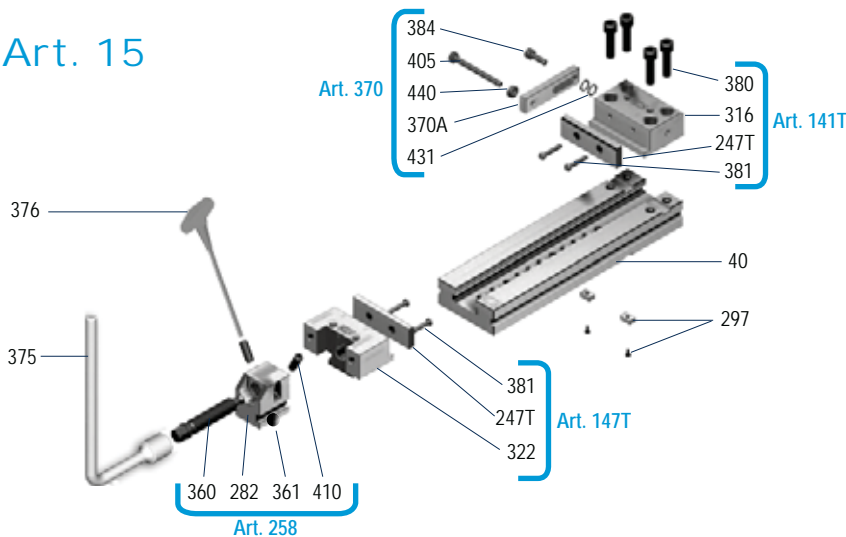

Art.	Pag.	Art.	Pag.
40	1.20	380	4.20
247T	4.9	381	4.20
282	4.28	384	4.20
297	4.27	405	4.27
316	4.22	410	4.28
322	4.22	431	4.20
360	4.28	440	4.20
361	4.28	-	-
370A	4.27	-	-
375	4.27	-	-
376	4.28	-	-

# MORSE e CUBI serie Standard FLEX Standard FLEX series VISES and CUBES

Pagg. 1.16 - 1.36

## Art. 1A

Morsa con piastre ganasce a cambio rapido manuale (Sistema a pettine)

Vise with quick manual change jaw plates (Comb system)

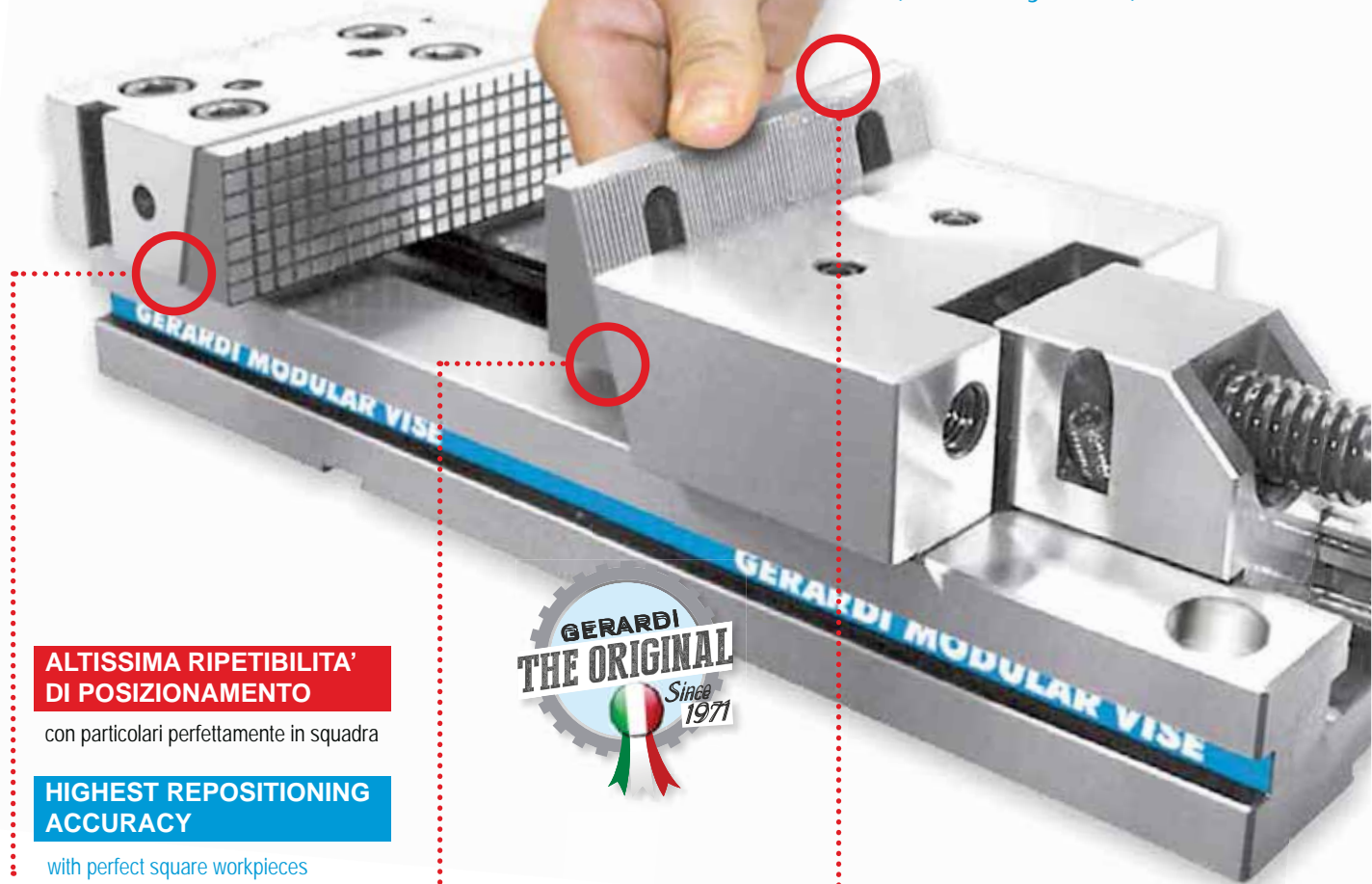

### ALTISSIMA RIPETIBILITA' DI POSIZIONAMENTO

con particolari perfettamente in squadra

### HIGHEST REPOSITIONING ACCURACY

with perfect square workpieces

### EFFETTO DISCENDENTE AMPLIFICATO E MIGLIORATO E MIGLIORE PROTEZIONE DAI TRUCIOLI

grazie al sistema a pettine

### INCREASED AND BETTER PULL DOWN ACTION AND BETTER PROTECTION FROM CHIPS

thanks to the comb system

### RICONFIGURAZIONE RAPIDISSIMA

grazie alla piastra ganascia intercambiabile manualmente

### GREAT SAVINGS IN VISE RESETTING TIMES

thanks to the manual interchangeable quick jaw plate

## CARATTERISTICHE E VANTAGGI

- USURA INESISTENTE
- RAPIDITA' DEI SERRAGGI
- MODULARITA' & VERSATILITA'
- PRECISIONI  $\pm 0,02$  mm
- RIGIDITA' & SICUREZZA
- DESIGN COMPATTO E MANEGGEVOLEZZA

Si rimanda a quanto esposto a pag. 1.2 e 1.3 (morse serie STANDARD)

## TECHNICAL FEATURES AND ADVANTAGES

- NO WEAR
- QUICK CLAMPING
- MODULARITY & VERSATILITY
- HIGHEST ACCURACIES  $\pm 0,02$  mm
- RIGIDITY & SAFETY
- SPACE SAVING DESIGN & HANDY

See pag. 1.2 and 1.3 (STANDARD series vises)

# La morsa più evoluta dotata del geniale sistema a pettine per la rapida sostituzione delle piastre ganasce discendenti!

## The most recent vise! Innovative comb system for quick pull-down jaw plate changes!

PIASTRE GANASCE DISCENDENTI INTERCAMBIABILI MANUALMENTE  
PULL DOWN JAW PLATES INTERCHANGEABLE BY HAND

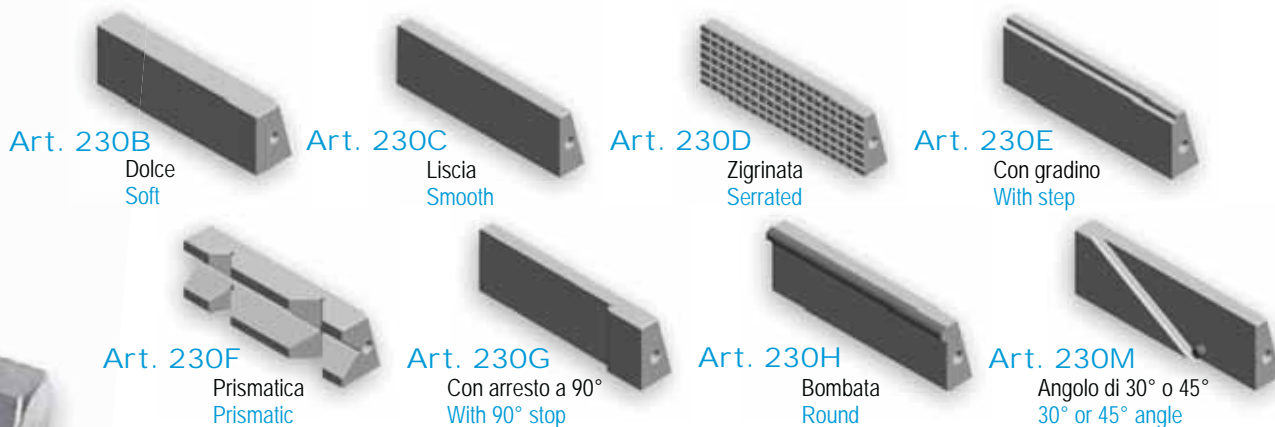

**"PORTAPIASTRE"**  
Completo di piastre ganasce a cambio rapido a gradino Art.230E  
**"THE RACK"**  
Complete of quick change step jaw plates Art.230E  
Vedi Pag. 4.14 - See Page.4.14



### POSSIBILITA' DI ACCOPPIAMENTO VERTICALE

### VERTICAL GANG OPERATION

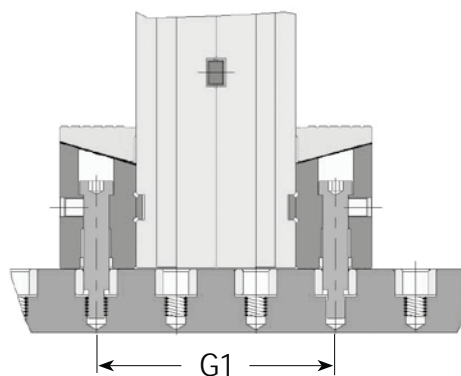
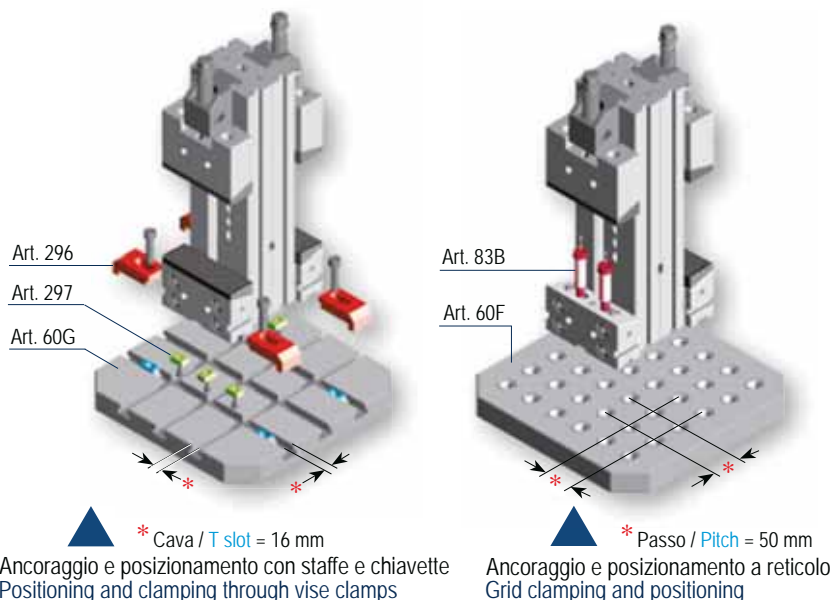

Tipo morsa / Vise type	3	4	5	6
G1 mm	150	200	250	

Esempio di montaggio in verticale di 2 morse StandardFLEX contrapposte su piani a reticolo Ø 16 mm. Passo 50 mm  
Example of version mounting of 2 StandardFLEX vises back to back on grid base Ø 16 mm. 50 mm Pitch



Tipo (grandezza) morsa / Vise (type) size	kN	1		2		3		4	
		16 kN	25 kN	30 kN	30 kN	30 kN	30 kN	30 kN	
Apertura massima / Maximum spread	A	100	150	200	300	200	300	400	500
<b>Art. 1A</b> Morsa <b>StandardFLEX</b> con piastre ganasce a cambio rapido manuale (Sistema a pettine)  <b>StandardFLEX vise with quick manual jaw plates change (Comb system)</b>	W	96	121	146		171			
	B	28	38	48		58			
	C	35	40	50		58			
	D	270	345	420	520	455	555	655	755
	G	75	95	125		145			
	kg	6.8	12.9	25.5	29	37	42	47	52
	Cod.	1.1A.10000	1.1A.20000	1.1A.32000	1.1A.33000	1.1A.42000	1.1A.43000	1.1A.44000	1.1A.45000

**AMPLIA LE TUE APPLICAZIONI TRAMITE GLI ACCESSORI MODULARI !**

Art. 230E Piastra ganasce intercambiabile Interchangeable jaw plate		Cod.		4.23.0E201		4.23.0E301		4.23.0E401	
		4.23.0E101	4.23.0E201	4.23.0E301	4.23.0E401	4.23.0E301	4.23.0E401		
H		23	33	43				53	
H1		5	5	5				5	

Art. 212 Ganasce mobile intermedia (da usare con Art. 230E) Intermediate movable jaw (to be used with Art. 230E)		Cod.		1.21.22000		1.21.23000		1.21.24000	
		1.21.21000	1.21.22000	1.21.23000	1.21.24000	1.21.23000	1.21.24000		

Art. 230B Piastra ganasce intercambiabile dolce Soft interchangeable jaw plate		Cod.		4.23.0B201		4.23.0B301		4.23.0B401	
		4.23.0B101	4.23.0B201	4.23.0B301	4.23.0B401	4.23.0B301	4.23.0B401		

Art. 230F Piastra ganasce intercambiabile prismatica Prismatic interchangeable jaw plate		Cod.		4.23.0F201		4.23.0F301		4.23.0F401	
		4.23.0F101	4.23.0F201	4.23.0F301	4.23.0F401	4.23.0F301	4.23.0F401		

Art. 271 Art. 403 Art. 393 <b>Art. 391</b> CNC / CNC <b>Art. 392</b> Pneumatico / Air control		Cod.		4.39.12000		4.39.13000		4.39.14000	
		4.39.11000	4.39.12000	4.39.13000	4.39.14000	4.39.21000	4.39.22000	4.39.23000	4.39.24000

Servocomandi oleopneumatici (completi di 1 cilindro e supporto) per serraggi multipli *contemporanei* o *indipendenti*, da 2 a 6 morse. Vedi pagg. 4.32, 4.33, 4.34

**Dotazione standard:**

- 1 arresto laterale Art. 370
- 1 coppia di tasselli di posizionamento Art. 297 (Standard per cava da 16 mm; altre dimensioni a richiesta senza variazione di prezzo)
- 2 tappi Art. 291 ■ 1 chiave a pipa Art. 375 ■ 1 chiave a "T" Art. 376

Fori rettificati e calibrati con tolleranza F7 già inclusi nel prezzo

**Art. 1A**

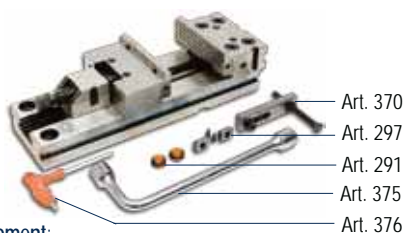

**Standard equipment:**

- 1 workstop Art. 370
- 1 pair of positioning key-nuts Art. 297 (Standard for 16 mm slot. Other dimensions available on request without price change)
- 2 inserts Art. 291 ■ 1 box wrench Art. 375 ■ 1 T-wrench Art. 376

Ground calibrated holes F7 tolerance already included in the price

**Art. 1A**

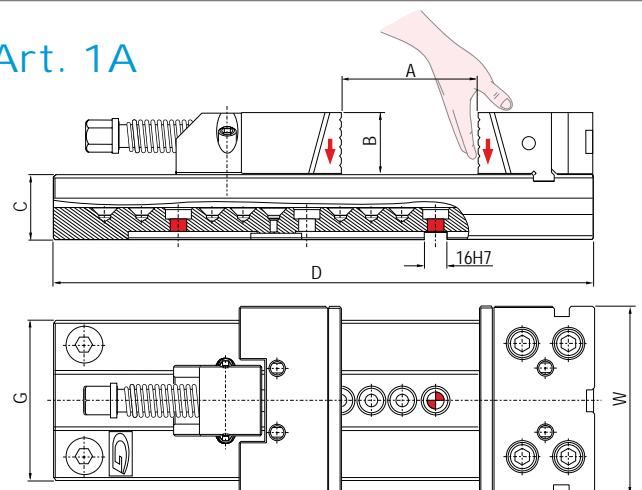

Vedi gruppo 4 per gamma completa accessori  
See group 4 for complete range of accessories





5 40 kN					6 40 kN						
200	300	400	500	600	200	300	400	500	600	700	800
196					296						
63					78						
70					78						
495	595	695	795	895	535	635	735	835	935	1035	1135
170					195						
64	69	74	79	84	95	105	115	125	135	145	155
1.1A.52000	1.1A.53000	1.1A.54000	1.1A.55000	1.1A.56000	1.1A.62000	1.1A.63000	1.1A.64000	1.1A.65000	1.1A.66000	1.1A.67000	1.1A.68000

**UPGRADE YOUR VISE APPLICATIONS THROUGH MODULAR ACCESSORIES !**

4.23.0E501		4.23.0E601
<b>Art. 230E</b>		
H	53	68
H1	10	10
1.21.25000		1.21.26000
<b>Art. 212</b>		
4.23.0B501		4.23.0B601
<b>Art. 230B</b>		
4.23.0F501		4.23.0F601
<b>Art. 230F</b>		
4.39.15000		4.39.16000
<b>Art. 391</b>		
4.39.25000		4.39.26000
<b>Art. 392</b>		

Pneumo-hydraulic servo units (complete of hydraulic cylinder + support) for multiple clamping simultaneous or independent, from 2 to 6 vises. *See pagg. 4.32, 4.33, 4.34*

**Art. 1A**

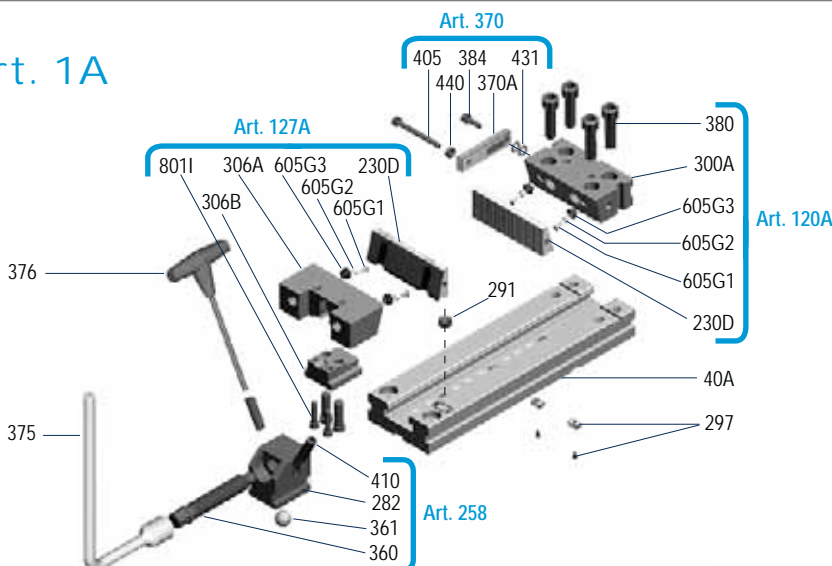

Art.	Pag.	Art.	Pag.
40A	1.20	376	4.27
230D	4.13	380	4.20
282	4.28	384	4.20
291	-	405	4.27
297	4.27	410	4.12
300A	4.22	431	4.20
306A	4.22	440	4.20
306B	4.22	605G1	6.31
360	4.28	605G2	6.31
361	4.28	605G3	6.31
370A	4.27	801I	5.54
375	4.27	-	-

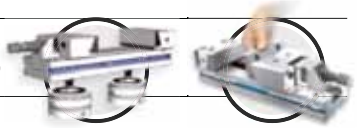

Tipo (grandezza) morsa / Vise (type) size		1		2		3		4	
	kN	16 kN	25 kN	30 kN		30 kN			
Apertura massima / Maximum spread	A	100	150	200	300	200	300	400	500
	W	96	121	146		171			
	B	28	38	48		58			
	C	35	40	50		58			
	D	270	345	420	520	455	555	655	755
	G	75	95	125		145			
	kg	7.3	13.2	26.2	29.7	37.9	43	48.1	53.2
	Cod.	1.1A.Z1000	1.1A.Z2000	1.1A.Z3200	1.1A.Z3300	1.1A.Z4200	1.1A.Z4300	1.1A.Z4400	1.1A.Z4500

**Art. 1AZ**

Morsa StandardFLEX per Zero Point con piastre ganasce a cambio rapido manuale

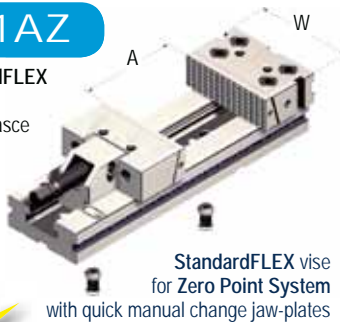

StandardFLEX vise for Zero Point System with quick manual change jaw-plates



**AMPLIA LE TUE APPLICAZIONI TRAMITE GLI ACCESSORI MODULARI !**

**Art. 230E**

Piastra ganasce intercambiabile Interchangeable jaw plate

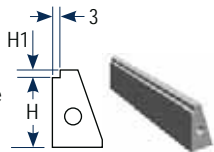

Cod.	4.23.0E101	4.23.0E201	4.23.0E301	4.23.0E401
H	23	33	43	53
H1	5	5	5	5

**Art. 212**

Ganascia mobile intermedia (da usare con Art. 230E) Intermediate movable jaw (to be used with Art. 230E)

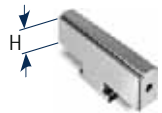

Cod.	1.21.21000	1.21.22000	1.21.23000	1.21.24000
------	------------	------------	------------	------------

**Art. 230B**

Piastra ganasce intercambiabile dolce Soft interchangeable jaw plate

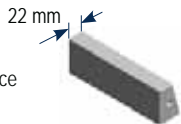

Cod.	4.23.0B101	4.23.0B201	4.23.0B301	4.23.0B401
------	------------	------------	------------	------------

**Art. 230F**

Piastra ganasce intercambiabile prismatica Prismatic interchangeable jaw plate



Cod.	4.23.0F101	4.23.0F201	4.23.0F301	4.23.0F401
------	------------	------------	------------	------------

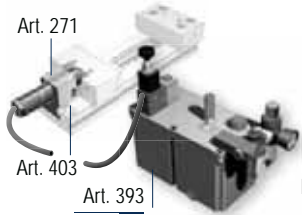

**Art. 391**  
CNC / CNC

**Art. 392**  
Pneumatico / Air control

Cod.	4.39.11000	4.39.12000	4.39.13000	4.39.14000
Cod.	4.39.21000	4.39.22000	4.39.23000	4.39.24000

Servocomandi oleopneumatici (completi di 1 cilindro e supporto) per serraggi multipli *contemporanei* o *indipendenti*, da 2 a 6 morse. Vedi pagg. 4.32, 4.33, 4.34

Dotazione standard:

- 1 arresto laterale Art. 370
- 2 tiranti Art. 10A
- 2 tappi Art. 291
- 1 chiave a pipa Art. 375
- 1 chiave a "T" Art. 376

**Art. 1AZ**

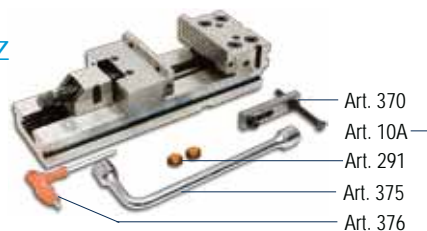

Standard equipment:

- 1 workstop Art. 370
- 2 pullstuds Art. 10A
- 2 inserts Art. 291
- 1 box wrench Art. 375
- 1 T-wrench Art. 376

**Art. 1AZ**

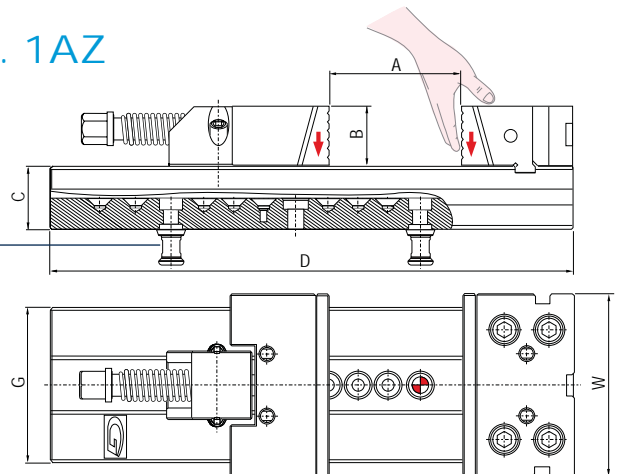

Vedi gruppo 4 per gamma completa accessori  
See group 4 for complete range of accessories

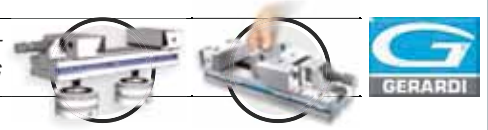

5 40 kN					6 40 kN						
200	300	400	500	600	200	300	400	500	600	700	800
196					296						
63					78						
70					78						
495	595	695	795	895	535	635	735	835	935	1035	1135
200					300						
65.3	70.3	75.3	80.3	85.3	97	107	117	127	137	147	157
1.1A.Z5200	1.1A.Z5300	1.1A.Z5400	1.1A.Z5500	1.1A.Z5600	1.1A.Z6200	1.1A.Z6300	1.1A.Z6400	1.1A.Z6500	1.1A.Z6600	1.1A.Z6700	1.1A.Z6800

**UPGRADE YOUR VISE APPLICATIONS THROUGH MODULAR ACCESSORIES !**

4.23.0E501		4.23.0E601
<b>Art. 230E</b>		
H	53	68
H1	10	10
1.21.25000		1.21.26000
<b>Art. 212</b>		
4.23.0B501		4.23.0B601
<b>Art. 230B</b>		
4.23.0F501		4.23.0F601
<b>Art. 230F</b>		
4.39.15000		4.39.16000
<b>Art. 391</b>		
4.39.25000		4.39.26000
<b>Art. 392</b>		

Pneumo-hydraulic servo units (complete of hydraulic cylinder + support) for multiple clamping simultaneous or independent, from 2 to 6 vises. *See pagg. 4.32, 4.33, 4.34*

**Art. 1AZ**

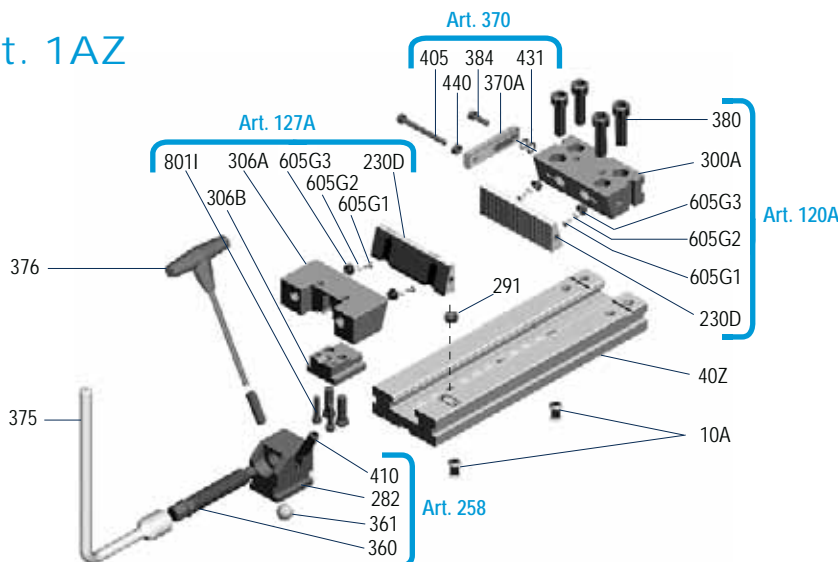

Art.	Pag.	Art.	Pag.
10A	9.25	376	4.27
40Z	1.20	380	4.20
230D	4.11	384	4.20
282	4.28	405	4.27
291	-	410	4.12
300A	4.27	431	4.20
306A	4.22	440	4.20
306B	4.22	605G1	6.31
360	4.28	605G2	6.31
361	4.26	605G3	6.31
370A	4.25	801I	5.54
375	4.25	-	-

Tipo (grandezza) morsa / Vise (type) size

### Art. 40

Slittone base serie **STD** senza alcuna dotazione



Vise base **STD** series supplied without any accessory

	1	2	3		4			
C	35	40	50		58			
D	270	345	420	520	455	555	655	755
G	75	95	125		145			
K	-	-	100		100			
N	2	3	3	4	3	4	5	6
U	111	111	122,5		129			
Z	100	100	100		100			
kg	3,8	7,3	15,1	18,7	20,6	25,2	29,7	34,5
Cod.	1.80.10270	1.80.20345	1.80.30420	1.80.30520	1.80.40455	1.80.40555	1.80.40655	1.80.40755

### Art. 40A

Slittone base serie **StandardFLEX** senza alcuna dotazione



Vise base **StandardFLEX** series supplied without any accessory

kg	3,8	7,3	15,1	18,7	20,6	25,2	29,7	34,5
Cod.	1.40.A1000	1.40.A2000	1.40.A3200	1.40.A3300	1.40.A4200	1.40.A4300	1.40.A4400	1.40.A4500

### Art. 40Z

Slittone base serie **Zero Point** senza alcuna dotazione



Vise base **Zero Point** series supplied without any accessory

ZZ	200	200	200	200/250	200	200/250	250/300	250/300
kg	4	8	15,5	19	21	25,5	30	35
Cod.	1.40.Z1000	1.40.Z2000	1.40.Z3200	1.40.Z3300	1.40.Z4200	1.40.Z4300	1.40.Z4400	1.40.Z4500

### Art. 62

Piastra di interfaccia per morse senza alcuna dotazione



Vise base connecting plate supplied without any accessory

C1	28	28	33		33			
UU	86	86	97,5	97,5	104	104	104	104
ZZ	200	200	200	200/250	200	200/250	250/300	250/300
kg	4,5	7,2	13,5	16,7	17	20,8	24,4	28,2
Cod.	1.62.11000	1.62.21500	1.62.32000	1.62.33000	1.62.42000	1.62.43000	1.62.44000	1.62.45000

### Art. 40

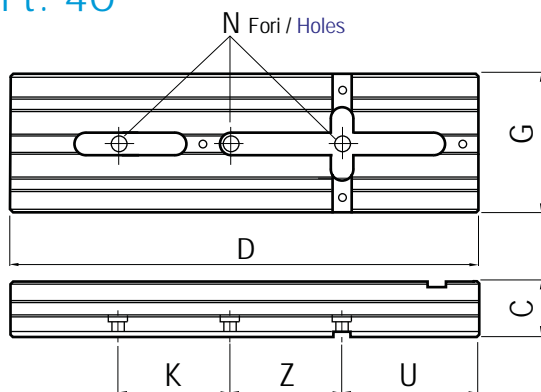

Versione normale: Cave da 16 mm (H7)  
Normal version: 16 mm slots (H7)

### Art. 40A

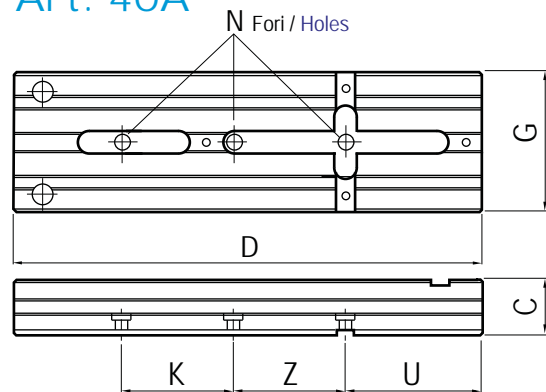

Versione normale: Cave da 16H7 e fori calibrati Ø8F7 (t.1) - Ø16F7 (t. 2 - 3 - 4 - 5 - 6)  
Normal version: 16H7 slot and calibrated holes Ø8F7 (t.1) - Ø16F7 (t. 2 - 3 - 4 - 5 - 6)



5					6						
70					78						
495	595	695	795	895	535	635	735	835	935	1035	1135
170					195						
100					100						
2	3	4	5	6	4	5	6	7	8	9	10
145					152						
100					100						
32,6	39,2	45,8	52,5	59	47	56	65	74	83	61	100
1.80.50495	1.80.50595	1.80.50695	1.80.50795	1.80.50895	1.80.60535	1.80.60635	1.80.60735	1.80.60835	1.80.60935	1.80.60035	1.80.60135

32,6	39,2	45,8	52,5	59	47	56	65	74	83	91	100
1.40.A5200	1.40.A5300	1.40.A5400	1.40.A5500	1.40.A5600	1.40.A6200	1.40.A6300	1.40.A6400	1.40.A6500	1.40.A6600	1.40.A6700	1.40.A6800

200	200/250	250/300	250/300	300	250/300	250/300	300	300	300	300	300
33	40	46	53	59	47	56	65	74	83	91	100
1.40.Z5200	1.40.Z5300	1.40.Z5400	1.40.Z5500	1.40.Z5600	1.40.Z6200	1.40.Z6300	1.40.Z6400	1.40.Z6500	1.40.Z6600	1.40.Z6700	1.40.Z6800

38					38						
120					127						
200	200/250	250/300	250/300	300	250/300	250/300	300	300	300	300	300
25	30	35	40	45	31	36,7	42,5	48,3	54	59,8	65,6
1.62.52000	1.62.53000	1.62.54000	1.62.55000	1.62.56000	1.62.62000	1.62.63000	1.62.64000	1.62.65000	1.62.66000	1.62.67000	1.62.68000

### Art. 40Z

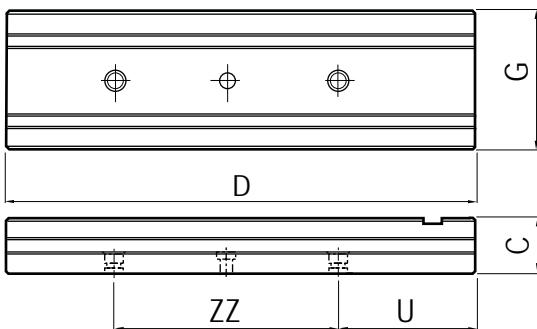

Versione normale: 2 o 3 fori filettati per tiranti Art. 10A  
 Normal version: 2-3 holes threaded for pull studs Art. 10A

### Art. 62

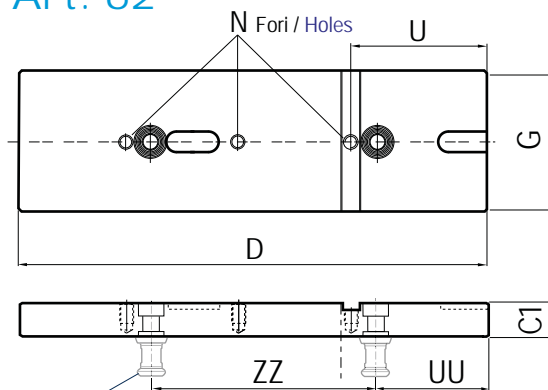

Art. 10A Tiranti Art. 10A non in dotazione  
 Pull studs Art. 10A not included in the standard equipment

Tipo (grandezza) morsa / Vise (type) size		1	2	3	4				
Tolleranza / Tolerance									
- 0,02	C	35	40	50	58				
-	D	270	345	420	520	455	555	655	755
- 0,02	F	10	12	13	15				
+ 0,02	F1	10	10	12	18				
- 0,02	G	75	95	125	145				
+ 0,02	Y	21	28	41	51				
-	Y1	31	41	57	70				
-	M	M10	M12	M14	M16				
-	N	76	76	84,5	89				
-	N1	35	35	38	40				
-	O	32	32	36	36				
-	P	19	19	20	22				
-	Q	50	62	88	100				
-	T	9,5	9,5	11,5	11,5				
-	T1	15	15	20	20				
-	T2	5	5	7	7				
-	U	111	111	122,5	129				
-	K	-	-	100	100				
-	Z	100	100	100	100				

**Art. 40** Slittone base serie **STD** / Vise base **STD** series

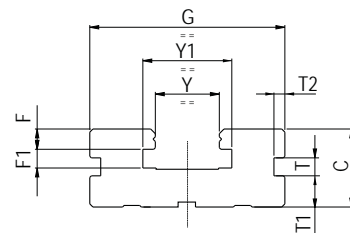
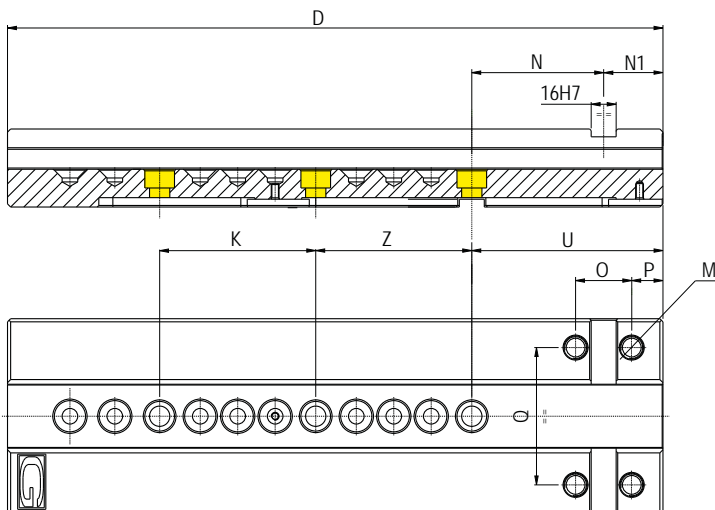

*Dettaglio foro per vite TCEI / TCEI screw hole details*

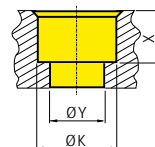

Type	1	2	3	4	5	6
X	4,5	5,5	8	8	17	17
ØY	6,5	8,5	13	13	17	17
ØK	10,5	13,5	19	19	26	26

**Art. 40A** Slittone base serie **StandardFLEX** / Vise base **StandardFLEX** series

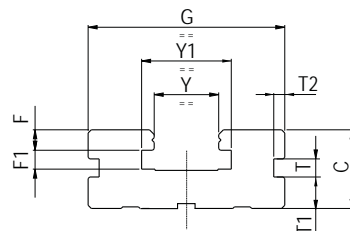
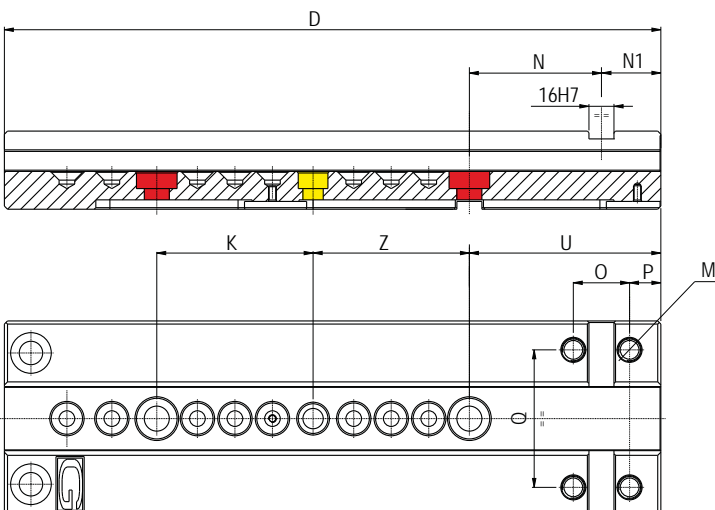

*Dettaglio foro per vite calibrata / Calibrated screw hole details*

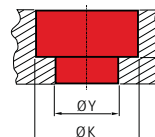

Type	1	2	3	4	5	6
X	8			11		
ØY	16F7			16F7		
ØK	21			25		

5					6							
		70						78				
495	595	695	795	895	535	635	735	835	935	1035	1135	
		20						20				
		18						18				
		170						195				
		61						71				
		80						90				
		M20						M20				
		100						107				
		45						45				
		44						44				
		23						23				
		120						133				
		17,5						17,5				
		26						26				
		10						10				
		145						152				
		100						100				
		100						100				

**Art. 40Z** Slittone base serie **ZERO POINT** / Vise base **ZERO POINT** series

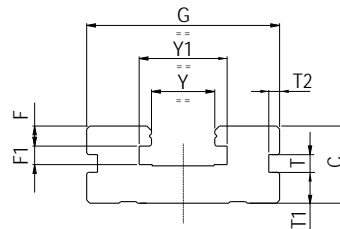
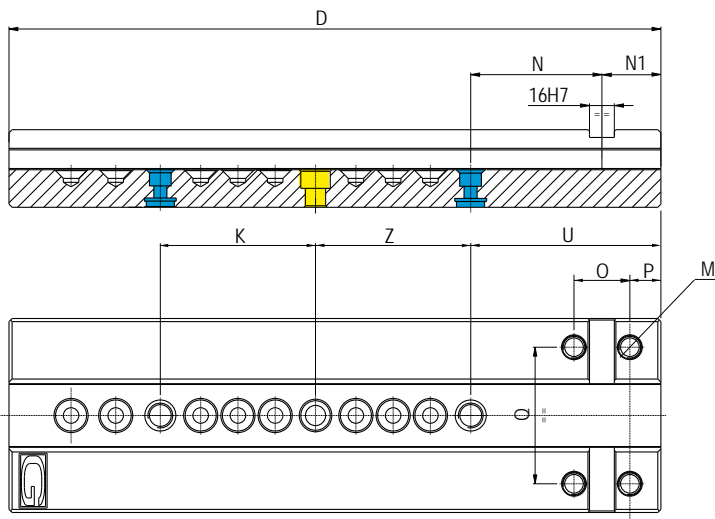

**Dettaglio foro per Zero Point / Zero Point hole details**

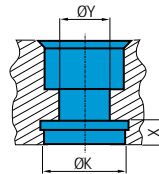

Type	1	2	3	4	5	6
X				6		
Ø Y				13		
Ø K				20		

Tolleranze generiche per morse XL / XL vise generic tolerances

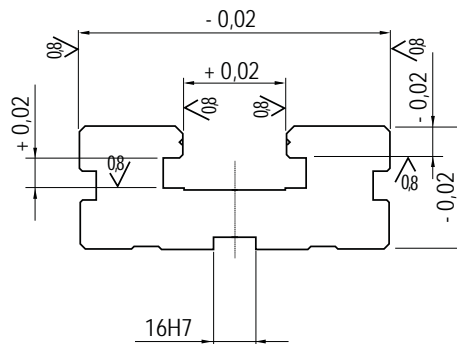
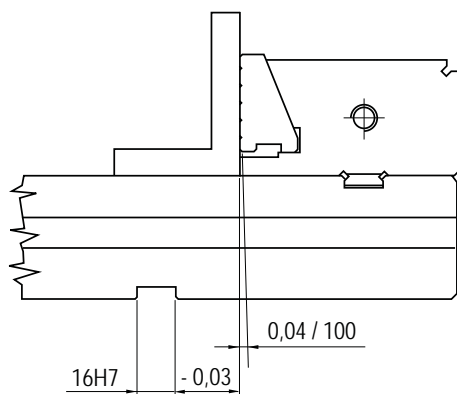

Tipo (grandezza) morsa / Vise (type) size

### Art. 700

Cubomorsa modulare standard in **monoblocco**

Standard modular vise tower in **solid body**

**Dotazione standard:**

- 4 arresti laterali Art. 370
- 2 coppie di tasselli di posizionamento Art. 297 (Standard per cava da 16 mm; altre dimensioni a richiesta senza variazione di prezzo)
- 1 chiave a pipa Art. 375
- 1 chiave a "T" Art. 376

**Standard equipment:**

- 4 workstops Art. 370
- 2 pairs of positioning key-nuts Art. 297 (Standard for 16 mm slot; other widths available on request without price change)
- 1 box wrench Art. 375
- 1 "T"- wrench Art. 376

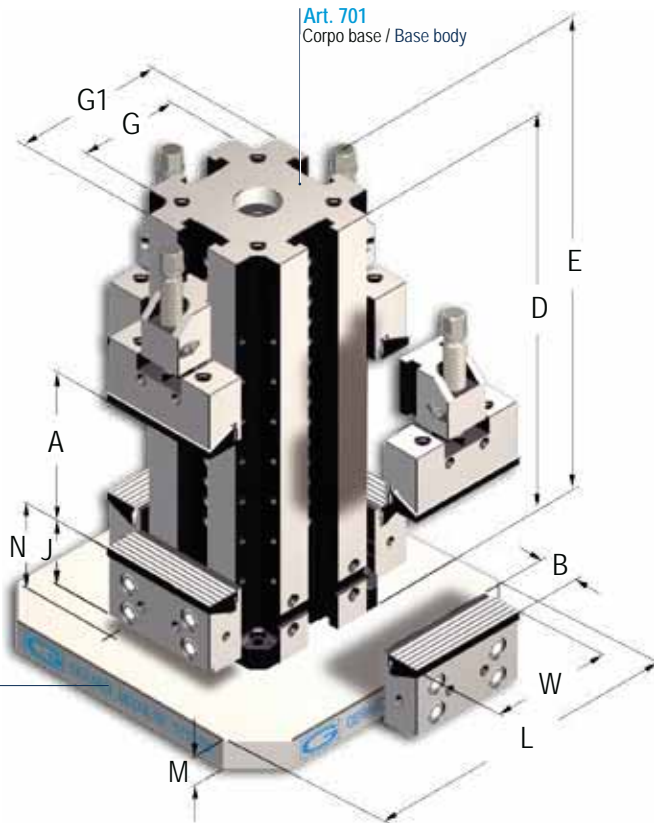

	1	
	kN	16 kN
A	80	130
W	100	
B	30	
D	250	300
E	300	350
G	75	
G1	120	
J	77,9	
L	300	
M	33	
N	85	
kg	37	42
Cod.	3.70.00801	3.70.01301

### Art. 828 (Extra)

Tipo (grandezza) morsa / Vise (type) size

Apertura massima / Maximum spread

### Art. 750

Morse standard montate verticalmente  
N° 4 morse STD Art. 1+ N° 1 Art. 450

Standard vises vertically mounted  
N° 4 vises STD Art. 1+ N° 1 Art. 450

**Dotazione standard:**

- 4 arresti laterali Art. 370
- 2 coppie di tasselli di posizionamento Art. 297 (Standard per cava da 16 mm; altre dimensioni a richiesta senza variazione di prezzo)
- 1 chiave a pipa Art. 375
- 1 chiave a "T" Art. 376

**Standard equipment:**

- 4 workstops Art. 370
- 2 pairs of positioning key-nuts Art. 297 (Standard for 16 mm slot; other widths available on request without price change)
- 1 box wrench Art. 375
- 1 "T"- wrench Art. 376

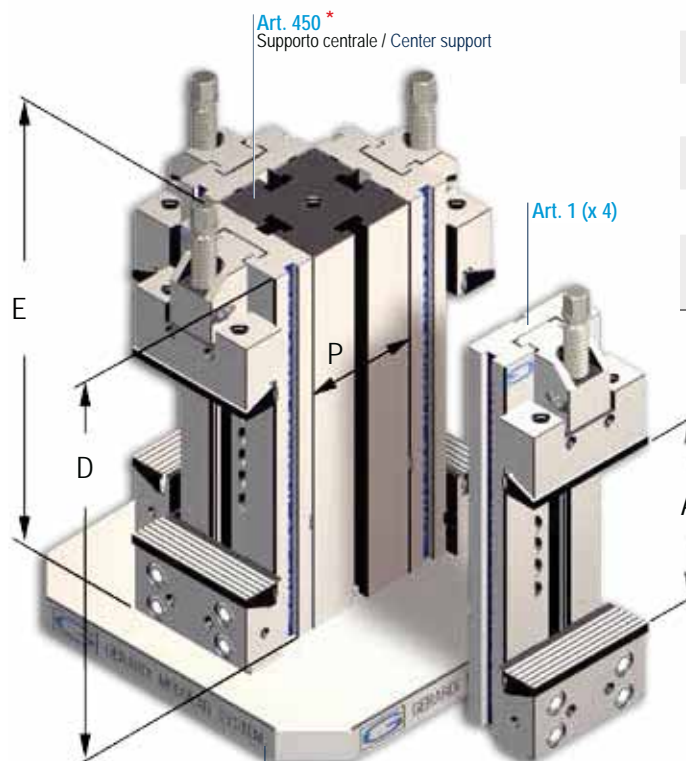

	1	
	kN	16 kN
A	100	
D	270 *	
E	320	
P	75 *	
kg	10	
Cod.	1.75.01000	

### Art. 828 (Extra)

\* Altre dimensioni a richiesta / Other dimensions on request

2 25 kN		3 30 kN			4 30 kN				5 40 kN	6 40 kN
155	205	170	270	370	145	245	345	445	-	-
125		150			175				200	300
40		50			60				-	-
350	400	400	500	600	400	500	600	700	-	-
430	480	470	570	670	475	575	675	775	-	-
95		125			145				170	195
160		190			230				*	*
77,9		89,4			96,9				*	*
350		400			450				*	*
33		38			38				-	-
85		102			111				-	-
83	96	137	160	183	197	230	263	296	-	-
3.70.01552	3.70.02052	3.70.01803	3.70.02803	3.70.03803	3.70.01454	3.70.02454	3.70.034 54	3.70.04454	-	-
									-	-

\* Altre dimensioni a richiesta / Other dimensions on request

2 25 kN	3 30 kN		4 30 kN				5 40 kN			6 40 kN		
150	200	300	200	300	400	500	200	300	400	300	400	500
345 *	420	520	455	555	655	755	495	595	695	635	735	835
345	450	550	455				-			-		
95 *	125		145				170			195		
19	46		68				98			145		
1.75.02000	1.75.03200	1.75.03300	1.75.04200	1.75.04300	1.75.04400	1.75.04500	1.75.05200	1.75.05300	1.75.05400	1.75.06300	1.75.06400	1.75.06500



Tipo (grandezza) morsa / Vise (type) size

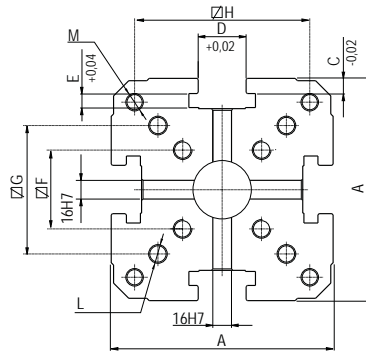

**Art. 701**

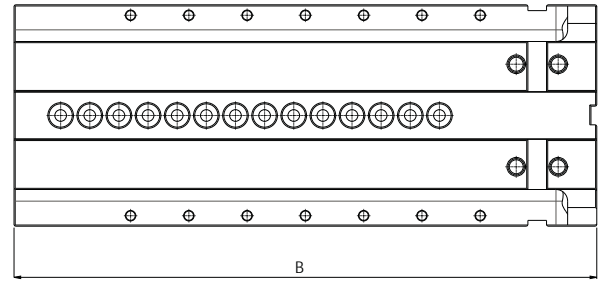

Senza alcuna dotazione  
Without accessory equipment

**Art. 701**

Corpo slittone standard  
Body for standard vise tower

Tipo (grandezza) morsa / Vise (type) size

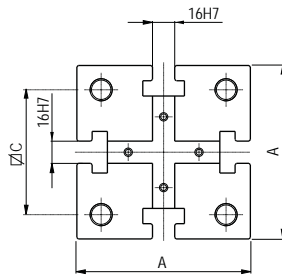

**Art. 450**



Senza alcuna dotazione  
Without accessory equipment

**Art. 450**

Supporto centrale per montaggio morse modulari standard in verticale. Dolce o temprato.  
Center support for vertical arrangement of standard modular vises. Soft or hardened

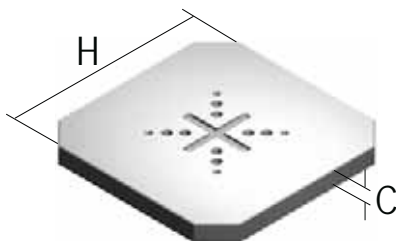

**Art. 828**

Piastra base per cubo-morsa  
Head plate for vise-tower

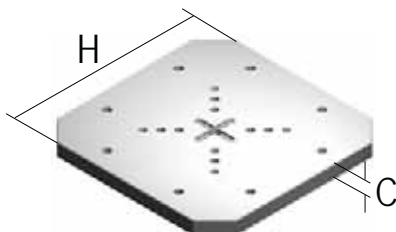

**Art. 828A**

Piastra base per cubo-morsa personalizzata  
Bussola di centraggio Art. 852 compresa  
Head plate for vise-tower tailor made  
Centering bushing Art. 852 included

	1		2		3			4				5	6
A	120		160		190			200				*	*
B	250	300	350	400	400	500	600	400	500	600	700	*	*
C	10		12		13			15				20	20
D	21		28		41			51				61	71
E	10		10		12			18				18	18
F	40		54		70			80				80	
G	70		84		110			134				134	
H	-		120		150			200				210	
L	M12		M16		M16			M20				M20	*
M	-		Ø 13		Ø 13			Ø 13				Ø 13	
kg	25	30	64	73	92	115	138	135	168	200	232	*	
Cod.	1.70.10801	1.70.11301	1.70.11552	1.70.12052	1.70.11803	1.70.12803	1.70.10803	1.70.11454	1.70.12454	1.70.13454	1.70.14454	*	
												-	-

\* A richiesta / On request

	1	2	3		4				5			6		
A	75	95	125		145				170			195		
B	270	345	420	520	455	555	655	755	495	595	695	635	735	835
C	50	60	90		110				110			*		
D	M12	M16	M16		M16				M20			*		
kg	10	19	46		68				98			145		
Cod.	1.45.01000	1.45.02000	1.45.03420	1.45.03520	1.45.04455	1.45.04555	1.45.04655	1.45.04755	1.45.05495	1.45.05595	1.45.05695	1.45.06635	1.45.06735	1.45.06835

\* A richiesta / On request

C	33	33	38	38	38	38
H	300	350	400	450	500	630
Cod.	5.82.81000	5.82.82000	5.82.83000	5.82.84000	5.82.85000	5.82.86000

C	33	33	38	38	38	38
H	300	350	400	450	500	630
Cod.	5.82.8A100	5.82.8A200	5.82.8A300	5.82.8A400	5.82.8A500	5.82.8A600

Art. 1

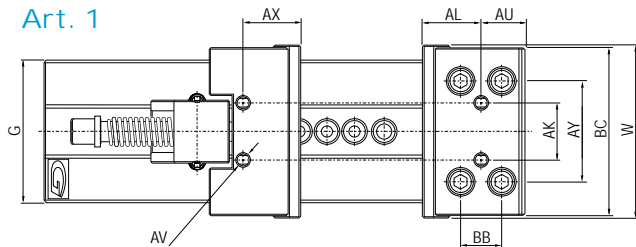

Art. 12

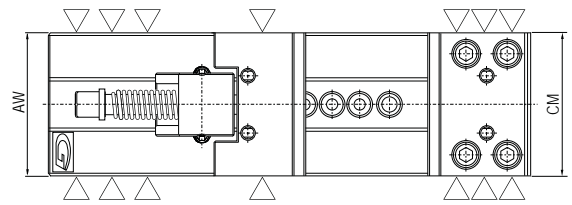

Art. 1+12

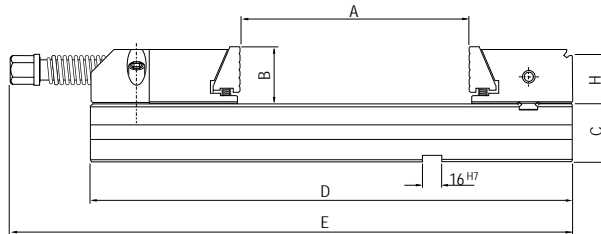

Tipo (grandezza) morsa / Vise (type) size

Tabella dimensionale / Table dimension

mm	1	2	3	4				5					6							
W	100	125	150	175				200					300							
A	100	150	200	300	200	300	400	500	200	300	400	500	600	200	300	400	500	600	700	800
B	30	40	50	60				65					80							
C	35	40	50	58				70					78							
D	270	345	420	520	455	555	655	755	495	595	695	795	895	535	635	735	835	935	1035	1135
E	320	425	500	600	530	630	730	830	580	680	780	880	980	630	730	830	930	1030	1130	1230
F	225	285	370	470	385	485	585	685	410	510	610	710	810	440	540	640	740	840	940	1040
G	75	95	125	145				170					195							
H	23	33	43	53				53					68							
I	55	70	110	160	110	160	210	260	105	165	205	265	305	115	165	215	265	315	365	415
J	34	50	70	104	70	104	137	170	67	107	134	174	200	74	107	140	174	207	240	274
K	124	174	226	326	226	326	426	526	236	336	436	536	636	236	336	436	536	636	736	836

mm	1	2	3	4	5	6	Tolleranza Tolerance	mm	1	2	3	4	5	6	Tolleranza Tolerance
L	54	77.9	89.4	96.9	113.4	120.4	- 0.04	AO	4.5	5.5	12.5	12.5	17	17	
M	72.9	72.9	84.4	91.9	108.4	115.4	- 0.04	AP	15	15	20	20	26	26	
N	10	10	12	18	18	18	+ 0.02	AQ	16	18	26	26	29	30	
O	27	27	30	32	37	37	± 0.02	AR	18	24	26	34	31	38	
P	38	50	62	72.5	83	120		AS	11	17	17	17	21	21	
R	65	80	100	118	135	158		AT	11	11	13	13	13	17	
S	18	23	29	37.5	37.5	47.5		AU	35.5	35.5	38.5	41.5	47	47	
T	16	20.5	27.5	36.5	34	46		AV	M8	M10	M12	M12	M16	M16	
U	111	111	122.5	129	145	152		AX	20	23	28	28	34	38	
V	76	76	84.5	89	100	107	± 0.02	AY	50	62	88	100	120	133	
W	-	-	100	100	100	100		AZ	M10	M12	M14	M16	M20	M20	
X	20	25	25	25	33.33	33.33		BB	32	32	36	36	44	44	
Y	21	28	41	51	61	71	+ 0.02	BC	96	121	146	171	196	296	
Z	100	100	100	100	100	100		BG	28	38	48	58	63	78	
AA	10	12	13	15	20	20	- 0.02	BJ	50	60	80	90	100	120	
AB	25.6	25.6	25.6	25.6	25.6	25.6	+ 0.02	BL	180	225	290	320	370	400	
AC	31	41	57	70	80	90		BM	9.5	9.5	11.5	11.5	17.5	17.5	
AD	53	73	81	101	113	135		CC	77	77	88.5	96	112	117	
AF	13	18	18	18	18	18		CD	48	58	78	88	98	117	
AG	M10	M16	M16	M16	M20	M20		CE	5	5	5	5	5	5	
AH	62	80	90	116	138	184		CF	-	-	64	64	71	-	
AI	M10	M10	M12	M12	M12	M12		CG	-	-	100	100	128	-	
AJ	14	19	24	29	31.5	39		CH	5.5	8	11	17	17	24	
AK	38	38	50	50	76	240		CI	24.5	32	39	43	48	56	
AX	25.6	42.4	50.1	55.4	66.4	73.4		CJ	12	12	13	13	18	18	
AL	42.4	42.4	50.9	55.4	66.4	73.4		-	-	-	-	-	-	-	
AM	4.5	5.5	12.5	12.5	17	17		-	-	-	-	-	-	-	
AN	10	13	19	19	25	25									

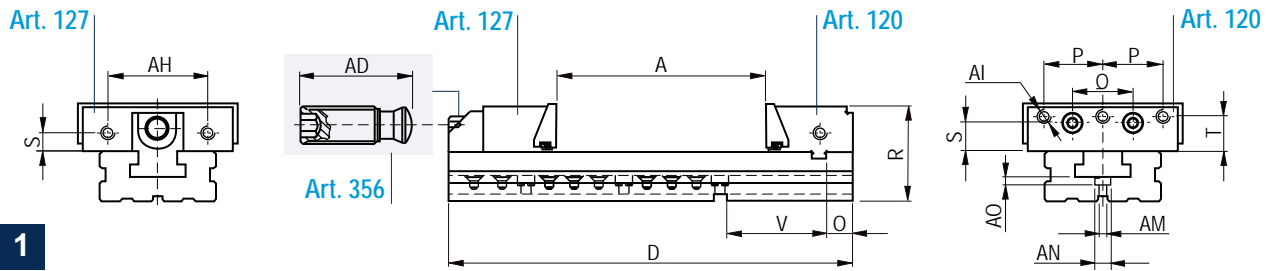

1

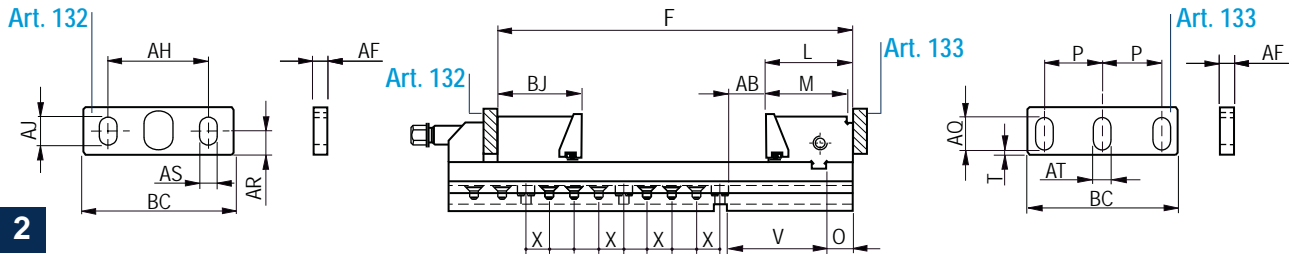

2

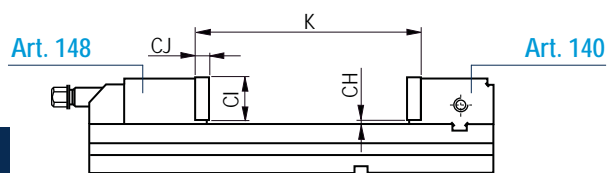

3

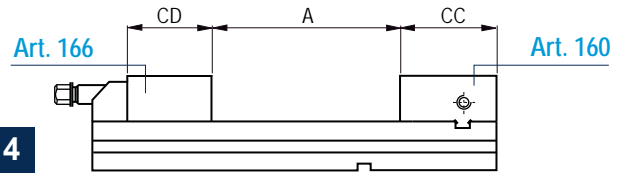

4

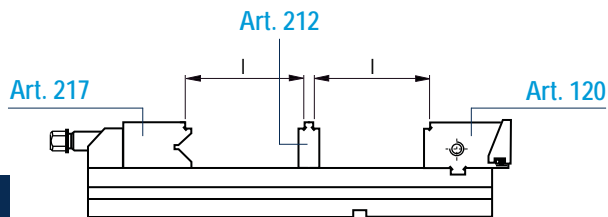

5

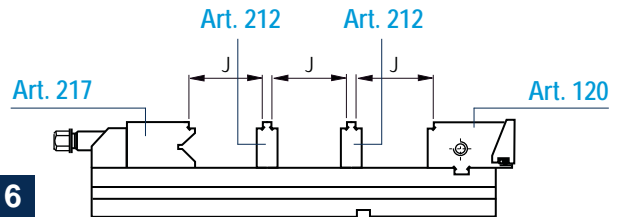

6

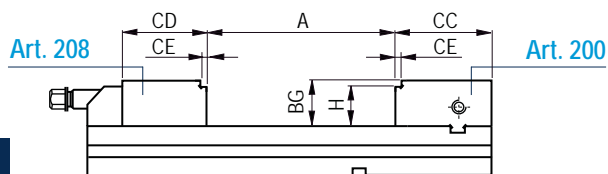

7

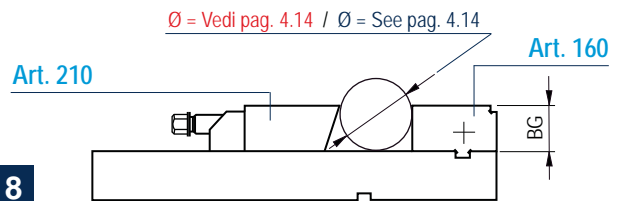

8

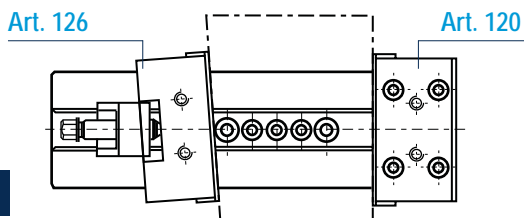

9

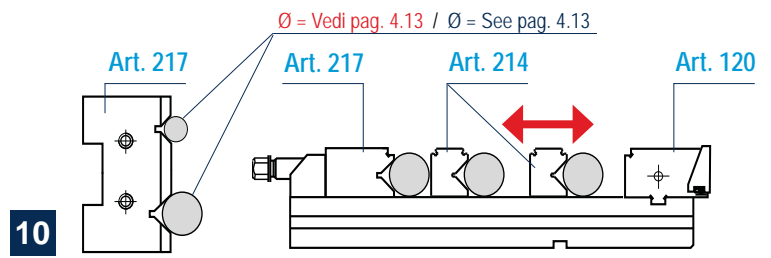

10

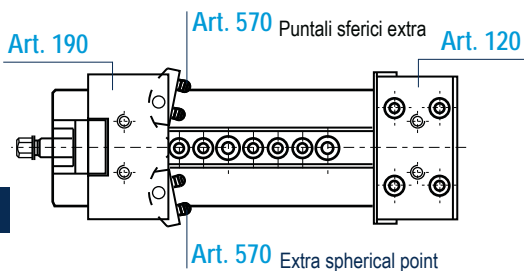

11

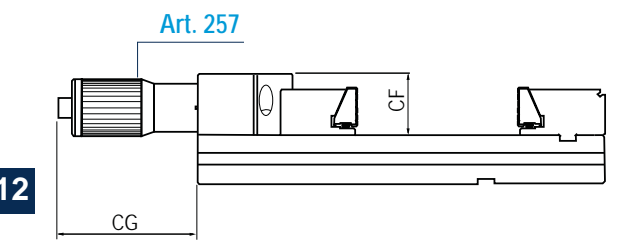

12

Tipo (grandezza) morsa / Vise (type) size	1	2	3	4	5	6
<b>Ganascia piana sovrapponibile fissa o mobile</b> <b>Straight stack-type jaw fixed or movable</b>  <b>Art. 130 (130S)</b> <i>Extra large / Extra width</i>						
	Cod. Art. 130 2.13.01000 2.13.02000 2.13.03000 2.13.04000 2.13.05000 2.13.06000 Cod. Art. 130S 2.13.0S100 2.13.0S200 2.13.0S300 2.13.0S400 2.13.0S500 2.13.0S600  Cad / Each					
<b>Ganascia sovrapponibile per pezzi tondi fissa o mobile</b> <b>Stack-type jaw round parts fixed or movable</b>  <b>Art. 131 (131S)</b> <i>Larghezza normale / Normal width</i> <b>Art. 131A (131AS)</b> <i>Larghezza super ridotta / Super narrow width</i>						
	Cod. Art. 131 2.13.11000 2.13.12000 2.13.13000 2.13.14000 2.13.15000 2.13.16000 Cod. Art. 131A 2.13.1A100 2.13.1A200 2.13.1A300 2.13.1A400 2.13.1A500 2.13.1A600  Cod. Art. 131S 2.13.1S100 2.13.1S200 2.13.1S300 2.13.1S400 2.13.1S500 2.13.1S600 Cod. Art. 131AS 2.13.1AS10 2.13.1AS20 2.13.1AS30 2.13.1AS40 2.13.1AS50 2.13.1AS60  Cad / Each					
<b>Ganascia piana sovrapponibile fissa o mobile</b> <b>Straight stack-type jaw fixed or movable</b>  <b>Art. 136 (136S)</b> <i>Larghezza normale / Normal width</i> <b>Art. 137 (137S)</b> <i>Larghezza super ridotta / Super narrow width</i>						
	Cod. Art. 136 2.13.61000 2.13.62000 2.13.63000 2.13.64000 2.13.65000 2.13.66000 Cod. Art. 137 2.13.71000 2.13.72000 2.13.73000 2.13.74000 2.13.75000 2.13.76000  Cod. Art. 136S 2.13.6S100 2.13.6S200 2.13.6S300 2.13.6S400 2.13.6S500 2.13.6S600 Cod. Art. 137S 2.13.7S100 2.13.7S200 2.13.7S300 2.13.7S400 2.13.7S500 2.13.7S600  Cad / Each					
<b>Ganascia a squadra sovrapponibile fissa o mobile</b> <b>Square stack-type jaw fixed or movable</b>  <b>Art. 138 (138S)</b> <i>Larghezza normale / Normal width</i> <b>Art. 139 (139S)</b> <i>Larghezza super ridotta / Super narrow width</i>						
	Cod. Art. 138 2.13.81000 2.13.82000 2.13.83000 2.13.84000 2.13.85000 2.13.86000 Cod. Art. 139 2.13.91000 2.13.92000 2.13.93000 2.13.94000 2.13.95000 2.13.96000  Cod. Art. 138S 2.13.8S100 2.13.8S200 2.13.8S300 2.13.8S400 2.13.8S500 2.13.8S600 Cod. Art. 139S 2.13.9S100 2.13.9S200 2.13.9S300 2.13.9S400 2.13.9S500 2.13.9S600  Cad / Each					
<b>Ganascia a squadra sovrapponibile doppia</b> <b>Double square jaw stack-type</b>  <b>Art. 138D (138DS)</b> <i>Larghezza normale / Normal width</i> <b>Art. 139D (139DS)</b> <i>Larghezza super ridotta / Super narrow width</i>						
	Cod. Art. 138D 2.13.8D100 2.13.8D200 2.13.8D300 2.13.8D400 2.13.8D500 2.13.8D600 Cod. Art. 139D 2.13.9D100 2.13.9D200 2.13.9D300 2.13.9D400 2.13.9D500 2.13.9D600  Cod. Art. 138DS 2.13.8DS10 2.13.8DS20 2.13.8DS30 2.13.8DS40 2.13.8DS50 2.13.8DS60 Cod. Art. 139DS 2.13.9DS10 2.13.9DS20 2.13.9DS30 2.13.9DS40 2.13.9DS50 2.13.9DS60  Cad / Each					
<b>Ganascia prismatica sovrapponibile fissa o mobile</b> <b>Stack-type prismatic jaw fixed or movable</b>  <b>Art. 150 (150S)</b> <i>Larghezza normale / Normal width</i> <b>Art. 150A (150AS)</b> <i>Larghezza super ridotta / Super narrow width</i>						
	Cod. Art. 150 1.15.01000 1.15.02000 1.15.03000 1.15.04000 1.15.05000 1.15.06000 Cod. Art. 150A 1.15.0A100 1.15.0A200 1.15.0A300 1.15.0A400 1.15.0A500 1.15.0A600  Cod. Art. 150S 1.15.0S100 1.15.0S200 1.15.0S300 1.15.0S400 1.15.0S500 1.15.0S600 Cod. Art. 150AS 1.15.0AS10 1.15.0AS20 1.15.0AS30 1.15.0AS40 1.15.0AS50 1.15.0AS60  Cad / Each					

Versione "S" in acciaio lavorabile / "S" type in soft steel

Esempi di applicazione / Typical arrangements

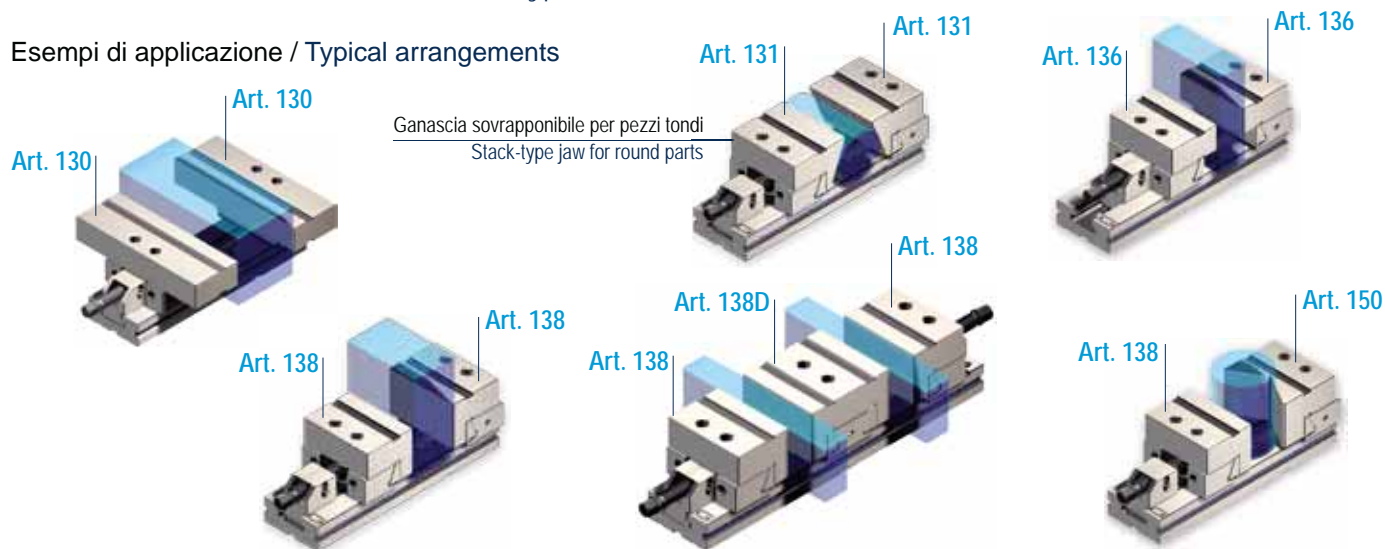

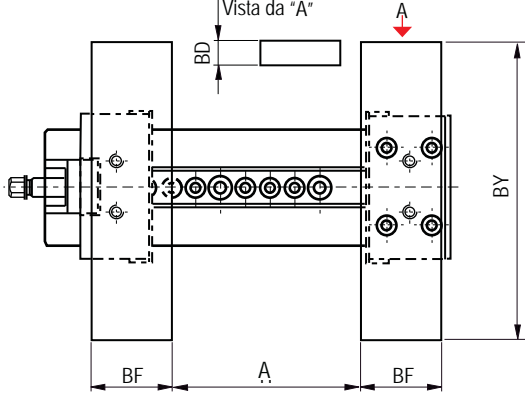
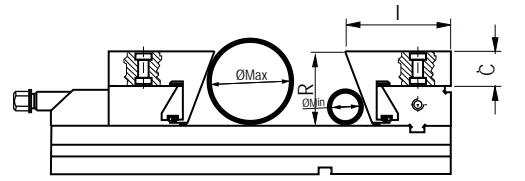
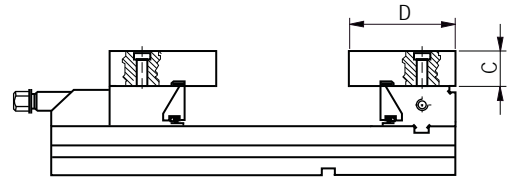
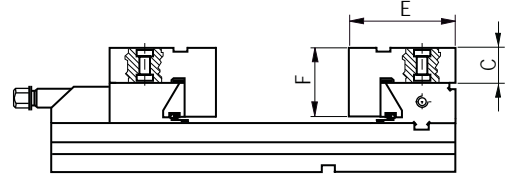
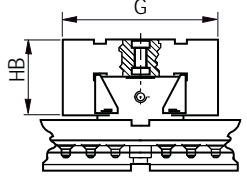
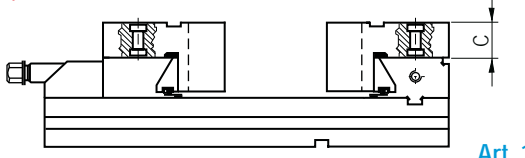
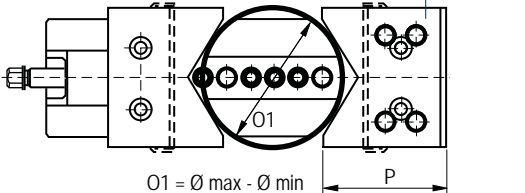

Tipo (grandezza) morsa / Vise (type) size	mm	1	2	3	4	5	6
<b>Art. 130</b> Temprate o in acciaio lavorabile / Hardened or soft	C	32	42	52	62	67	82
	D	84	84	105	130	130	150
	E	80	88	105	110	130	135
	F	57	70	90	110	128	150
	G	110	110	140	171	192,8	190
	I	95	95	123	136	170	206
<b>Art. 131 / 131A</b> Temprate o in acciaio lavorabile / Hardened or soft	BD	32	42	52	62	72	82
	BF	80	80	105	120	128	135
	BY	200	250	300	350	400	600
	P	84	120	120	140	175	206
<b>Art. 136 / 137</b> Temprate o in acciaio lavorabile / Hardened or soft	R	60	78	90	110	128	150
	O1 min	26	32	38	45	55	75
	O1 max	160	200	240	280	360	500
<b>Art. 138 / 139</b> Temprate o in acciaio lavorabile / Hardened or soft	W	96	121	146	171	196	296
	Q	30	30	30	30	30	30
	O2 min	33	43	49	60	70	
	O2 max	75	100	130	160	180	220
<b>Art. 138D / 139D</b> Temprate o in acciaio lavorabile / Hardened or soft							
							
<b>Art. 150 / 150A</b> Temprate o in acciaio lavorabile / Hardened or soft							
							
							

**ISTRUZIONI PER UN CORRETTO UTILIZZO**  
**INSTRUCTIONS FOR A PROPER USE**

**POSIZIONAMENTO**

Le morse della serie *STANDARD* e *StandardFLEX* possono essere posizionate orizzontalmente oppure in verticale sulla tavola della macchina o su sovratavola.

Il **posizionamento** e l'**allineamento** avviene tramite chiavette a 16 H7. Si può anche allineare la morsa tramite viti calibrate, garantendo tolleranze centesimali. (No per tipo 1e2).



Tavola macchina con cave a "T"  
Machine table with T-slots

\* La dotazione standard comprende 1 sola coppia di tasselli di posizionamento Art. 297  
 Standard equipment includes only 1 pair of positioning key nuts Art. 297

**POSITIONING**

*STANDARD* and *StandardFLEX* series vises can be aligned on the machine table horizontally or vertically mounted.

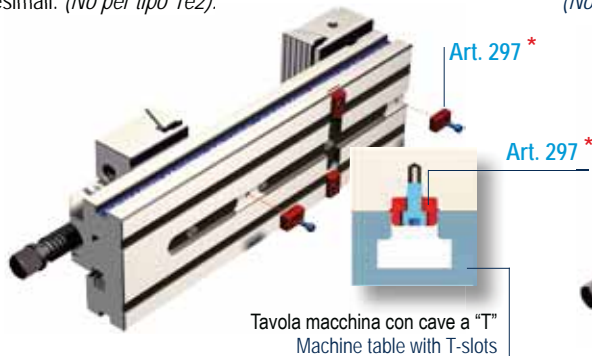
Accurate **positioning** and **alignment** within centesimal tolerances is made through 16 H7 longitudinal or crossway keys. It is also possible to align the vise through calibrated ground screws (Not for types 1 and 2).



Tavola macchina con reticolo  
Machine table grid type

**CONTROLLO ALLINEAMENTO TRA CAVA TRASVERSALE E GANASCIA FISSA**

Posizionare la morsa verticalmente assicurandosi che sia perfettamente parallela al piano di appoggio **A** nei due sensi. Successivamente, con un comparatore centesimale, controllare il parallelismo del piano cava e della ganascia fissa.

**ALIGNMENT BETWEEN THE CROSS KEYWAY AND THE FIXED JAW PLATE**

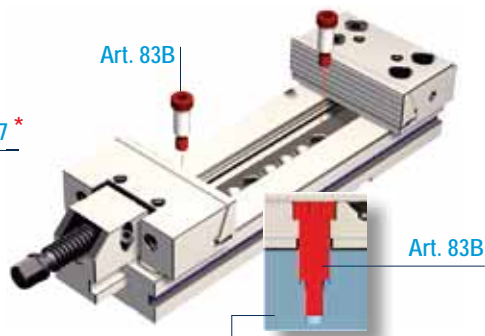
Set the vise vertically ensuring that it is perfectly at parallel to the table **A** in both sides. Then with an indicator check the parallelism of the keyway and its alignment with the fixed jaw plate.

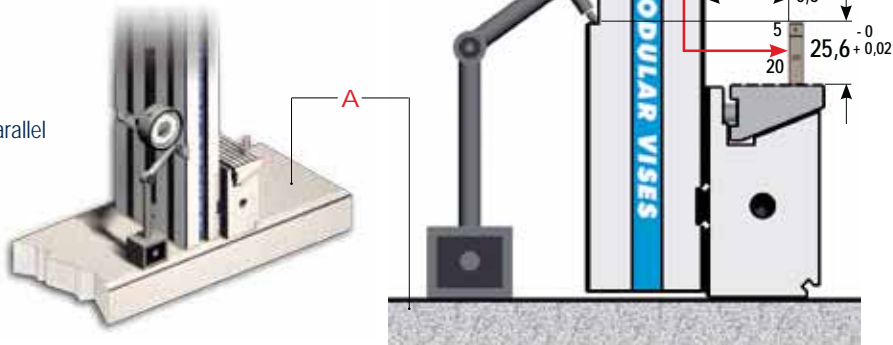

**ANCORAGGIO**

L'ancoraggio può avvenire tramite viti centrali o staffe laterali. **La scelta più valida rimane comunque il fissaggio tramite staffe laterali (Art. 296).**

Due morse parallele allineate tramite chiave centrale, viti calibrate o riferimenti laterali, mantengono lo stesso riferimento sulle ganasce fisse con tolleranza pari a 0,02 mm.

**WISE CLAMPING ON THE MACHINE TABLE**

The clamping on the machine table can be made through screws from the central groove or through side clamps.

The best clamping choice is through side clamps (Art. 296). Two vises aligned through central cross keys or ground screws or side lateral reference points guarantee the same reference and alignment on the fixed jaw section with accuracy within 0,02 mm.

Lo staffaggio della morsa con questo metodo **NON** è consigliabile perché la sua quota X può flettere e compromettere lo scorrimento della ganascia mobile su questo asse

Hard tightening down of the vise to the machine table by this method is **NOT** recommended as it can distort gap X and prevent the moving jaw from sliding

Per morsa tipo 3, forza consigliata massima 50 Nm per vite

Suggested max torque 50 Nm each screw for type 3 vise

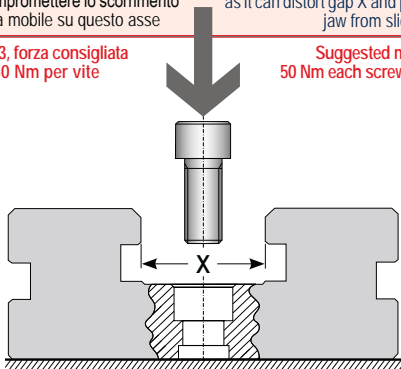

**IL METODO CORRETTO E' QUESTO**

**THIS IS THE RIGHT WAY**

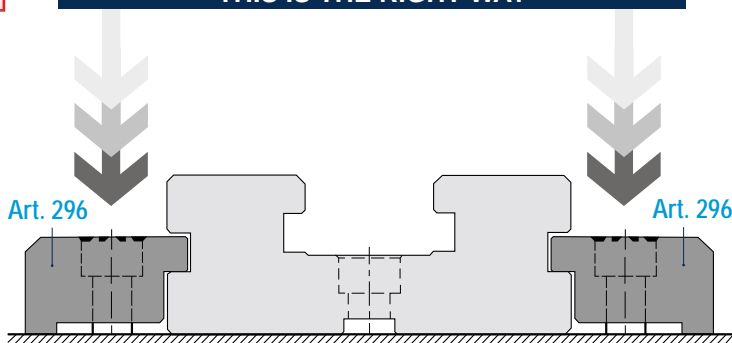

**ISTRUZIONI PER UN CORRETTO UTILIZZO****INSTRUCTIONS FOR A PROPER USE****OPERAZIONI PER UN CORRETTO SERRAGGIO DEI PEZZI***Le illustrazioni si riferiscono all' Art. 1 "STANDARD"*

1 - Assicurarsi che la morsa sia correttamente posizionata e ancorata alla tavola della macchina e che la ganaschia fissa Art. 120 / 120A sia correttamente fissata. (Fig. 1)

**ACTIONS FOR THE BEST WORK-PIECE CLAMPING***Pictures refer to Art. 1 "STANDARD" vise*

1 - Ensure that the vise is properly positioned and clamped to the machine table and that the fixed jaw Art.120 / 120A is properly assembled. (Pic.1)

**Fig. 1 Pic. 1**

2- Posizionare la ganaschia mobile Art. 127 / 127A allentando i due grani Art. 410 per consentire il sollevamento della sfera calibrata Art. 361 e quindi lo spostamento di tutto il gruppo di serraggio Art. 258 in una posizione più idonea sullo slittone di base, lasciando circa 5 mm di aria rispetto al pezzo da serrare. (Fig. 2)

2 - Position the movable jaw Art.127 / 127A loosening the 2 set screws Art.410 in order to allow the ground ball Art.361 lift and then move the Art.258 blocking group in the most proper position on the vise base leaving roughly 5 mm space with respect to the workpiece to clamp. (Pic.2)

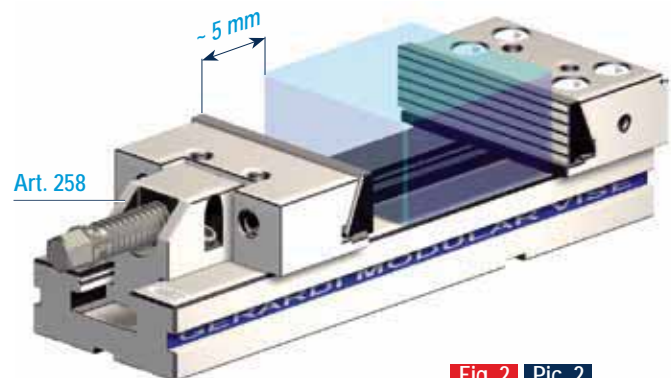
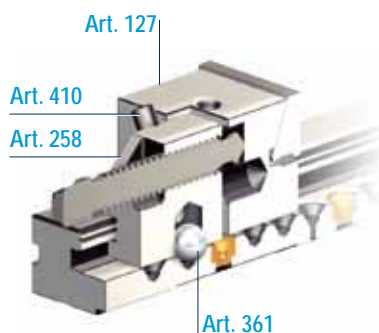
**Fig. 2 Pic. 2**

3- Nello stringere i due grani Art. 410 mediante la chiave Art. 376, (agendo in senso orario) per assicurarsi che la sfera di posizionamento Art. 361, sia correttamente posizionata in una sede sferica.

Fare attenzione che tale sfera non venga posizionata in una incassatura delle viti di ancoraggio. E' possibile posizionare l'apposito inserto Art. 291 con sede sferica per prevenire incastri. (Fig. 3)

3 - Tightening the 2 set screws Art.410 through the T-wrench Art.376 to ensure that the positioning ball Art.361 is properly positioned in a spherical recess.

Be careful that the positioning ball is not pushed in the hole used for the vise clamping screws. It is also possible to use a proper insert Art. 291 with spherical recess in order to prevent bad blocking of the ball. (Pic. 3)

**Fig. 3 Pic. 3**

**ISTRUZIONI PER UN CORRETTO UTILIZZO**  
**INSTRUCTIONS FOR A PROPER USE**

**UTILIZZO DELL' OPZIONE "EFFETTO DISCENDENTE"**

4 - Nel caso di morse Art. 1, volendo avvalersi della opzione piastre ganasce discendenti, allentare di 1/4 di giro le viti Art. 381 / 382 ( Fig. 4) per permettere alle piastre ganasce discendenti Art. 230 di scorrere dall' alto verso il basso, ottenendo così un serraggio del pezzo verso la base morsa.

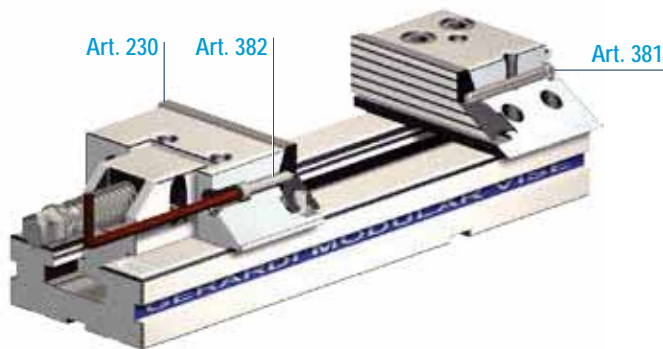

Solo per morse Standard - Only for Standard Vises

Allentando le viti di 1/4 di giro si ha un sollevamento della piastra della ganasca Art. 230 grazie alla spinta della molla Art. 362.

Loosening the screws of 1/4 of a turn you get a jaw plate Art.230 lift because of the spring Art.362 action.

**"PULL DOWN" ACTION OPTION**

4 - Using Art. 1 vises, if the pull down option is required, loose of 1/4 of a turn the screws Art.381 / 382 ( Pic.4) in order to allow the jaw plates Art.230 to run downward getting a perfect clamping of the workpiece against the vise base.

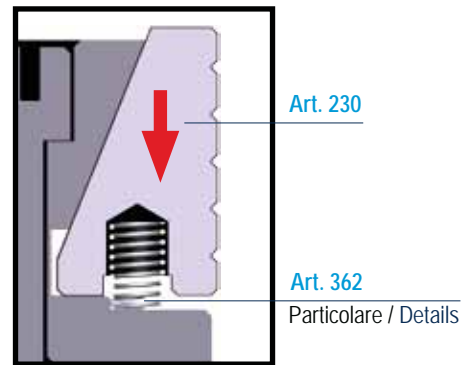

Fig. 4 Pic. 4

5 - Posizionare il pezzo da serrare sullo slittone Art. 40 o 40A e tenerlo contro la ganasca fissa Art. 120 o 120A. Per un corretto posizionamento del pezzo ci si può avvalere dei riferimenti laterali Art. 370. (Fig. 5)

5 - Position the workpiece on the vise base Art.40 or 40A and push it against the fixed jaw Art.120 or 120A. For a proper workpiece positioning you can use the work-stop Art.370. (Pic.5)

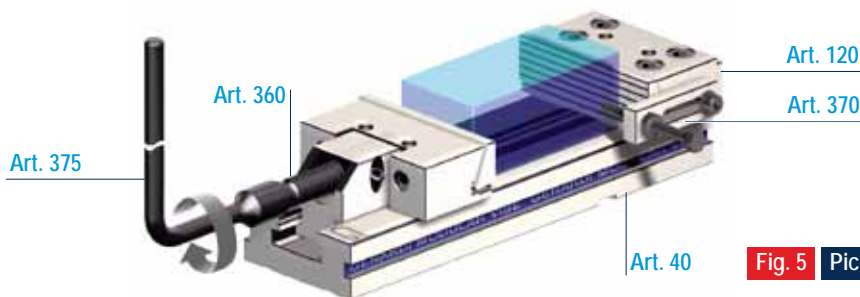

Fig. 5 Pic. 5

6 - Serrare il pezzo agendo in senso orario sulla vite di spinta Art. 360 (Fig. 5) mediante la chiave in dotazione Art. 375 senza utilizzare tubi o martelli. Attenzione: nel serraggio basta 1/4 di giro della chiave dal momento in cui la ganasca tocca il particolare (valori indicativi in tabella). (Fig. 6)

6 - Clamp the workpiece turning clockwise the main spindle Art.360 through the box wrench Art.375 without using tubes or hammers. Attention: for the right clamping operation 1/4 of a turn of the box wrench is enough (see table below). (Pic.6)

Valori indicativi delle forze di serraggio raggiunte a 90°  
 Clamping force indicative values at 90°

Tipo (grandezza) Type (size)	1	2	3	4	5	6
Kn	1,2	2,6	3,6	4,6	5	5

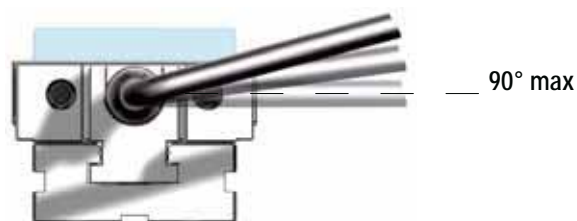
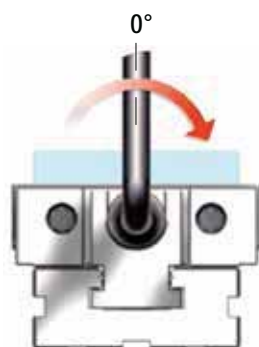

Fig. 6 Pic. 6



## COME SERRARE IL PEZZO

## HOW TO CLAMP A WORKPIECE

Per serrare correttamente il pezzo è consigliabile utilizzare una chiave dinamometrica da regolare in base al tipo di morsa e alla forza che si vuole ottenere.

### AVVERTENZA

Per una maggior precisione e ripetibilità delle lavorazioni, attenersi alle seguenti disposizioni:

- 1 Serrare il particolare con una chiave dinamometrica, regolata secondo la tabella "PROVE DI SERRAGGIO".
- 2 Individuare il momento ideale tramite comparatore posizionato sul pezzo, quindi procedere nelle lavorazioni richieste.
- 3 Serrare eventuali particolari simili con la medesima forza di serraggio.

In order to clamp the work-piece in the most proper way it is recommended the use of a torque wrench to be adjusted according to the vise type and the clamping power desired or needed.

### WARNING

For an increased machining accuracy and repetability use the following instructions:

- 1 Clamp the workpiece with a torque wrench set according to the "CLAMPING TEST" table.
- 2 Set the right torque through a clock indicator positioned on the workpiece, then proceed with the machining operations.
- 3 Clamp next similar workpieces with the same clamping power.

### PROVE DI SERRAGGIO / CLAMPING TEST Art. 1 e Art. 1A

Eseguite a temperatura ambiente (20°) con chiave dinamometrica  
Test made with 20° temperature with torque wrench

*Esempio: con una morsa TIPO 3, applicando con chiave dinamometrica un momento di 60 Nm, si ottiene una forza di serraggio di 25 Kn*  
*Example: with a vise TYPE 3 (jaw width 150 mm), using torque wrench set at 60 Nm, you can get a clamping power of 25 Kn*

TIPO TYPE	Momento applicato = Nm Wrench power = Nm	Forza di serraggio = Kn Clamping force = Kn
1	30	10
	50	16 MAX
2	20	8
	40	16
3 / 4	60	25 MAX
	40	16
5 / 6	60	25
	80	30 MAX
	80	30
	120	40 MAX

### TOLLERANZE GEOMETRICHE

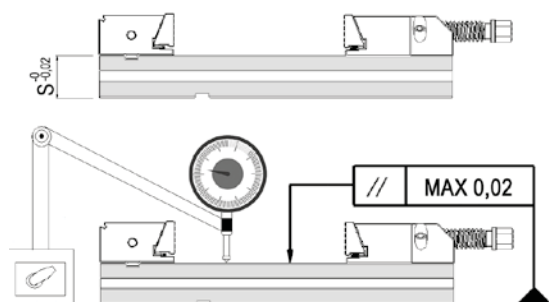

### GEOMETRIC ACCURACIES

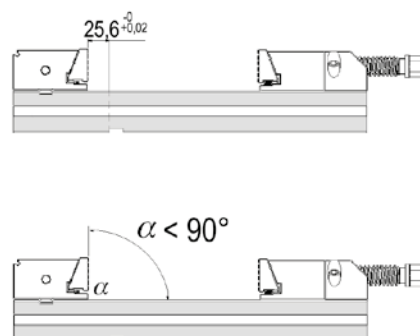

### TOLLERANZE DINAMICHE

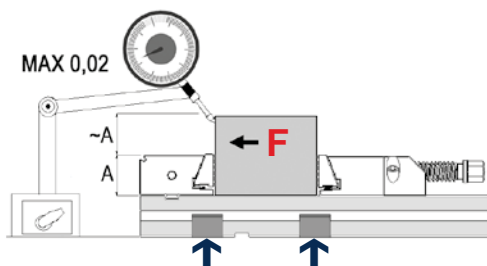

### DINAMIC ACCURACIES

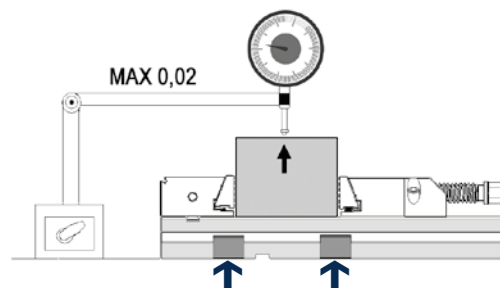

Morsa ancorata con 2 coppie di staffe Art. 296 / Vise clamped with n. 2 pairs of Art. 296

Valori di flessione nel punto "A" in relazione alle forze di serraggio **PER MORSE TIPO 3**  
Deflection values at "A" in relation to clamping powers **FOR TYPE 3 VISES**

60 kn	0.1 mm
50 kn	0.07 mm
40 kn	0.05 mm
30 kn	0.03 mm
20 kn	0.02 mm
10 kn	0.01 mm
5 kn	0.004 mm
2 kn	0.002 mm

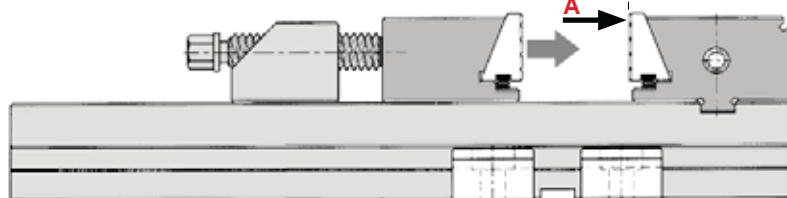

1 kgf . m = 9.806 Nm



**SERRAGGIO MECCANICO CON CHIAVE DINAMOMETRICA**

**MECHANICAL CLAMPING WITH TORQUE WRENCH**

GRUPPI DI SERRAGGIO MECCANICI (Art. 258 e similari)

MECHANICAL CLAMPING DEVICES (Art. 258 and similar)

I diagrammi seguenti consentono di determinare le forze di serraggio ottenibili con le morse di varia grandezza (da 1 a 6), in funzione del momento applicato

The following diagrams give the clamping force that can be obtained with each vise type (size 1 to 6) depending on the torque

**MORSE STD e StandardFLEX TIPO 1**  
**STD and StandardFLEX VISES TYPE 1**

Vite M14 - Passo 2 mm  
Screw M14 - Pitch 2 mm

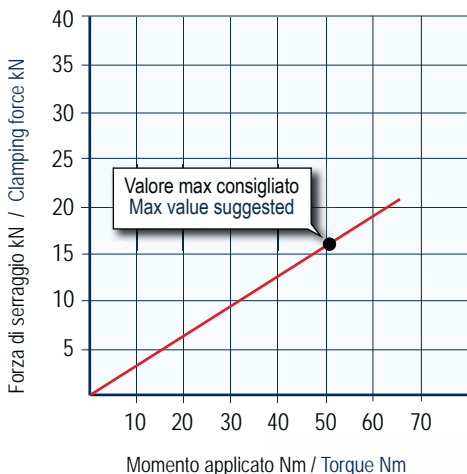

**MORSE STD e StandardFLEX TIPO 2**  
**STD and StandardFLEX VISES TYPE 2**

Vite Ø 18 - Passo 4 mm  
Screw Ø 18 - Pitch 4 mm

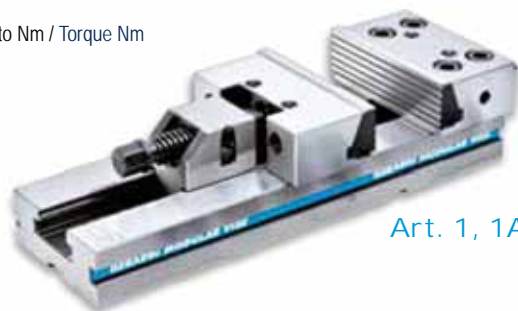
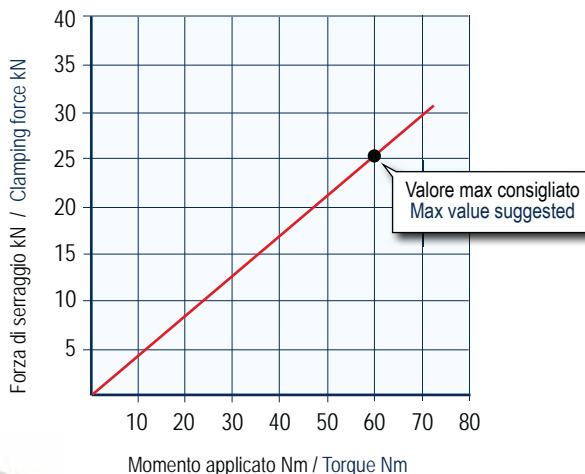

Art. 1, 1A, 700

**MORSE STD e StandardFLEX TIPO 3-4**  
**STD and StandardFLEX VISES TYPE 3-4**

Vite Ø 24 - Passo 5 mm  
Screw Ø 24 - Pitch 5 mm

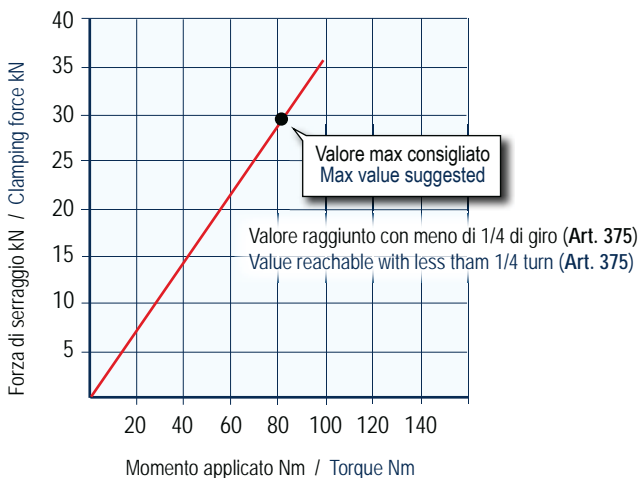

**MORSE STD e StandardFLEX TIPO 5-6**  
**STD and StandardFLEX VISES TYPE 5-6**

Vite Ø 30 - Passo 5 mm  
Screw Ø 30 - Pitch 5 mm

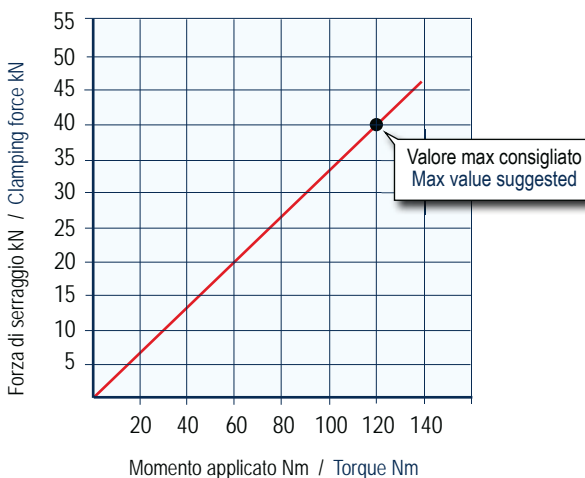

NB: Alcuni fattori, come la lubrificazione, lo staffaggio, gli attriti ed altro, possono modificare i valori indicati fino a  $\pm 10\%$ .  
Per un corretto utilizzo non superare i valori indicati nel grafico

Some factor as lubrication, clamping on the machine table, frictions and more can modify above values within a  $\pm 10\%$  range. For optimum operation do not exceed chart values.

MORSE MODULARI DI PRECISIONE  
PRECISION MODULAR VISES

OK

MORSE serie OK  
OK series VISES



3 MICRONS ACCURACY

# MORSE serie OK

## OK series VISES

Una serie di morse per le esigenze più impegnative e per lavori con le tolleranze più ristrette  
A series of vises for the highest accuracy operations

### L'ALTISSIMA PRECISIONE E' OK THE HIGHEST ACCURACY VISE IS OK

#### Principali caratteristiche delle morse serie OK

- Superfici rettificate, temperate e lappate
- Ortogonalità e parallelismo: 0,003 mm / 100 mm
- Ideali per operazioni di controllo, rettifica, elettroerosione e fresatura

#### Main OK vises technical features

- All case hardened and hardened HRC 60 steel
- Squareness and parallelism: 0,003 mm / 100 mm
- Ideal for grinding E.D.M. machine and for milling operations also for checking and control



3 MICRONS ACCURACY

Tipologia (grandezza) morsa / Vise (type) size		0	1	2	3	4	5	6	7	8
	kN			160 kN	160 kN	180 kN	180 kN	180 kN	180 kN	200 kN
Apertura massima / Maximum spread	A	27	80	100	120	160	180	200	260	200
	W	30	60	75	100	125	125	125	125	160
	B	15	28	40	45	50	50	50	50	63
	C	15	28	35	42	50	50	50	50	63
	D	75	175	220	260	330	350	370	430	410
	E	15	40	50	55	65	65	65	65	80
	F	33	55	50	85	105	105	105	110	130
	kg	0,28	2,820	5,820	10,740	19,450	20,080	20,720	26,720	38
	Cod.	3.66.60000	3.66.61000	3.66.62000	3.66.63000	3.66.64000	3.66.65000	3.66.66000	3.66.67000	3.66.68000

### Art. 666

Morsa serie OK in acciaio / Series OK vises in steel

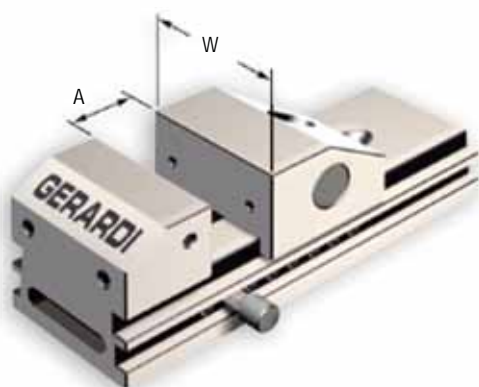

### Art. 666S

Morsa serie OK in acciaio Tipo \*X4 CR14 per elettroerosione. Stesse caratteristiche dell'Art. 666

Series OK vises in steel Type X4 CR14 for E.D.M. machines. Same characteristic and dimension of the Art. 666

\* Acciaio temprato a basso contenuto di ferro (Max resistenza alla corrosione dopo tempra, rinvenimento e rettifica)  
Low carbon hardened steel (max resistance against corrosion after hardening process and grinding operations)

Cod. 3.66.6S000 3.66.6S100 3.66.6S200 3.66.6S300 3.66.6S400 3.66.6S500 3.66.6S600 3.66.6S700 3.66.6S800

#### Dotazione standard:

- 4 staffe di fissaggio Art. 666O
- 1 arresto laterale fisso Art. 666G ■ 1 arresto laterale mobile Art. 666I

#### Art. 666 / Art. 666S

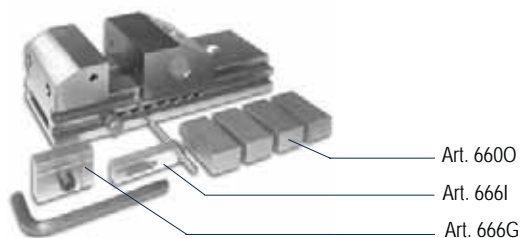

#### Standard equipment:

- 4 clamping jaws Art. 666O
- 1 fixed work stop Art. 666G ■ 1 movable work stop Art. 666I

### Art. 666 / Art. 666S

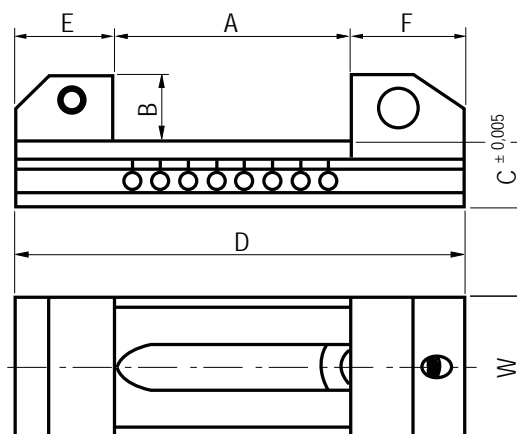

Tipo (grandezza) morsa / Vise (type) size	0	1	2	3	4	5	6	7	8
			160 kN	160 kN	180 kN	180 kN	180 kN	180 kN	200 kN

**Parti di ricambio per Art. 666 / Spare parts for Art. 666**

**Art. 666**

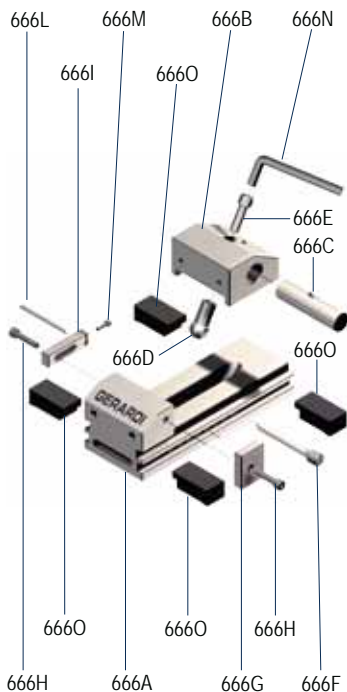

Art. 666A	Cod.	7.66.6A000	7.66.6A100	7.66.6A200	7.66.6A300	7.66.6A400	7.66.6A500	7.66.6A600	7.66.6A700	7.66.6A800
Art. 666B	Cod.	7.66.6B000	7.66.6B100	7.66.6B200	7.66.6B300	7.66.6B400	7.66.6B500	7.66.6B600	7.66.6B700	7.66.6B800
Art. 666C	Cod.	7.66.6C000	7.66.6C100	7.66.6C200	7.66.6C300	7.66.6C400	7.66.6C500	7.66.6C600	7.66.6C700	7.66.6C800
Art. 666D	Cod.	7.66.6D000	7.66.6D100	7.66.6D200	7.66.6D300	7.66.6D400	7.66.6D500	7.66.6D600	7.66.6D700	7.66.6D800
Art. 666E	Cod.	7.66.6E000	7.66.6E100	7.66.6E200	7.66.6E300	7.66.6E400	7.66.6E500	7.66.6E600	7.66.6E700	7.66.6E800
Art. 666F	Cod.	7.66.6F000	7.66.6F100	7.66.6F200	7.66.6F300	7.66.6F400	7.66.6F500	7.66.6F600	7.66.6F700	7.66.6F800
Art. 666G	Cod.	7.66.6G000	7.66.6G100	7.66.6G200	7.66.6G300	7.66.6G400	7.66.6G500	7.66.6G600	7.66.6G700	7.66.6G800
Art. 666H	Cod.	7.66.6H000	7.66.6H100	7.66.6H200	7.66.6H300	7.66.6H400	7.66.6H500	7.66.6H600	7.66.6H700	7.66.6H800
Art. 666I	Cod.	7.66.6I000	7.66.6I100	7.66.6I200	7.66.6I300	7.66.6I400	7.66.6I500	7.66.6I600	7.66.6I700	7.66.6I800
Art. 666L	Cod.	7.66.6L000	7.66.6L100	7.66.6L200	7.66.6L300	7.66.6L400	7.66.6L500	7.66.6L600	7.66.6L700	7.66.6L800
Art. 666M	Cod.	7.66.6M000	7.66.6M100	7.66.6M200	7.66.6M300	7.66.6M400	7.66.6M500	7.66.6M600	7.66.6M700	7.66.6M800
Art. 666N	Cod.	7.66.6N000	7.66.6N100	7.66.6N200	7.66.6N300	7.66.6N400	7.66.6N500	7.66.6N600	7.66.6N700	7.66.6N800
Art. 666O	Cod.	7.66.6O000	7.66.6O100	7.66.6O200	7.66.6O300	7.66.6O400	7.66.6O500	7.66.6O600	7.66.6O700	7.66.6O800

Tipo (grandezza) morsa / Vise (type) size	0	1	2	3	4	5	6	7	8
			160 kN	160 kN	180 kN	180 kN	180 kN	180 kN	200 kN

**Parti di ricambio in acciaio inox per Art. 666S / Spare parts in stainless steel for Art. 666S**

**Art. 666S**

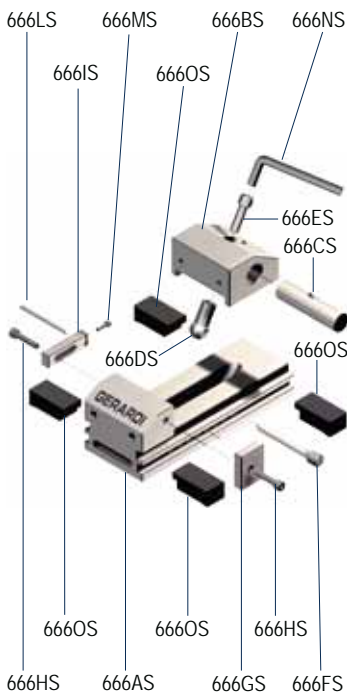

Art. 666AS	Cod.	7.66.6AS00	7.66.6AS10	7.66.6AS20	7.66.6AS30	7.66.6AS40	7.66.6AS50	7.66.6AS60	7.66.6AS70	7.66.6AS80
Art. 666BS	Cod.	7.66.6BS00	7.66.6BS10	7.66.6BS20	7.66.6BS30	7.66.6BS40	7.66.6BS50	7.66.6BS60	7.66.6BS70	7.66.6BS80
Art. 666CS	Cod.	7.66.6CS00	7.66.6CS10	7.66.6CS20	7.66.6CS30	7.66.6CS40	7.66.6CS50	7.66.6CS60	7.66.6CS70	7.66.6CS80
Art. 666DS	Cod.	7.66.6DS00	7.66.6DS10	7.66.6DS20	7.66.6DS30	7.66.6DS40	7.66.6DS50	7.66.6DS60	7.66.6DS70	7.66.6DS80
Art. 666ES	Cod.	7.66.6ES00	7.66.6ES10	7.66.6ES20	7.66.6ES30	7.66.6ES40	7.66.6ES50	7.66.6ES60	7.66.6ES70	7.66.6ES80
Art. 666FS	Cod.	7.66.6FS00	7.66.6FS10	7.66.6FS20	7.66.6FS30	7.66.6FS40	7.66.6FS50	7.66.6FS60	7.66.6FS70	7.66.6FS80
Art. 666GS	Cod.	7.66.6GS00	7.66.6GS10	7.66.6GS20	7.66.6GS30	7.66.6GS40	7.66.6GS50	7.66.6GS60	7.66.6GS70	7.66.6GS80
Art. 666HS	Cod.	7.66.6HS00	7.66.6HS10	7.66.6HS20	7.66.6HS30	7.66.6HS40	7.66.6HS50	7.66.6HS60	7.66.6HS70	7.66.6HS80
Art. 666IS	Cod.	7.66.6IS00	7.66.6IS10	7.66.6IS20	7.66.6IS30	7.66.6IS40	7.66.6IS50	7.66.6IS60	7.66.6IS70	7.66.6IS80
Art. 666LS	Cod.	7.66.6LS00	7.66.6LS10	7.66.6LS20	7.66.6LS30	7.66.6LS40	7.66.6LS50	7.66.6LS60	7.66.6LS70	7.66.6LS80
Art. 666MS	Cod.	7.66.6MS00	7.66.6MS10	7.66.6MS20	7.66.6MS30	7.66.6MS40	7.66.6MS50	7.66.6MS60	7.66.6MS70	7.66.6MS80
Art. 666NS	Cod.	7.66.6NS00	7.66.6NS10	7.66.6NS20	7.66.6NS30	7.66.6NS40	7.66.6NS50	7.66.6NS60	7.66.6NS70	7.66.6NS80
Art. 666OS	Cod.	7.66.6OS00	7.66.6OS10	7.66.6OS20	7.66.6OS30	7.66.6OS40	7.66.6OS50	7.66.6OS60	7.66.6OS70	7.66.6OS80

**SERRAGGIO MECCANICO CON CHIAVE DINAMOMETRICA**

**MECHANICAL CLAMPING WITH TORQUE WRENCH**

I diagrammi seguenti consentono di determinare le forze di serraggio ottenibili con le morse di varia grandezza (da 2 a 8), in funzione del momento applicato

The following diagrams give the clamping force that can be obtained with each vise type (size 2 to 8) depending on the torque

**MORSE OK TIPO 2**  
**OK VISES TYPE 2**

Chiave dinamometrica BETA 610/10X  
Torque wrench BETA 610/10X

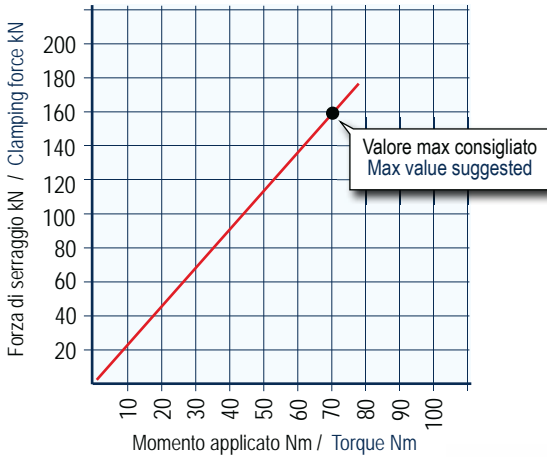

**MORSE OK TIPO 3**  
**OK VISES TYPE 3**

Chiave dinamometrica BETA 610/10X  
Torque wrench BETA 610/10X

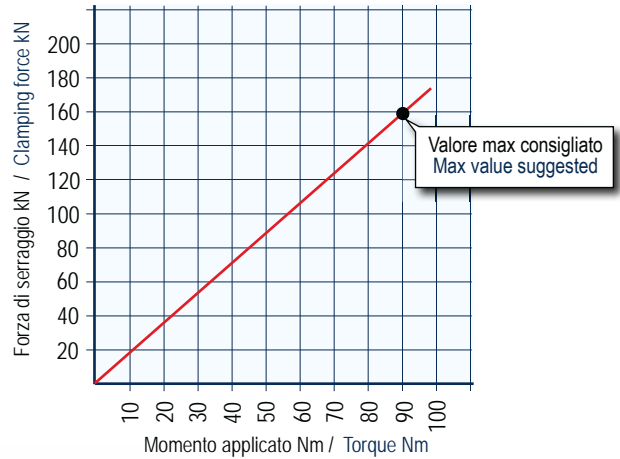

Art. 666 - Art. 666S

**MORSE OK TIPO 4-5-6-7**  
**OK VISES TYPE 4-5-6-7**

Chiave dinamometrica BETA 610/10X  
Torque wrench BETA 610/10X

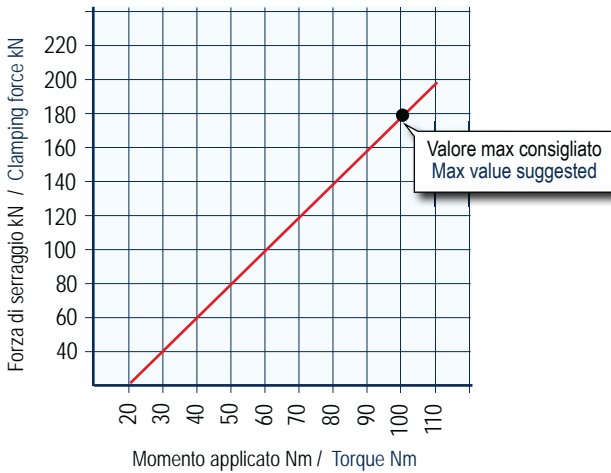

**MORSE OK TIPO 8**  
**OK VISES TYPE 8**

Chiave dinamometrica BETA 610/10X  
Torque wrench BETA 610/10X

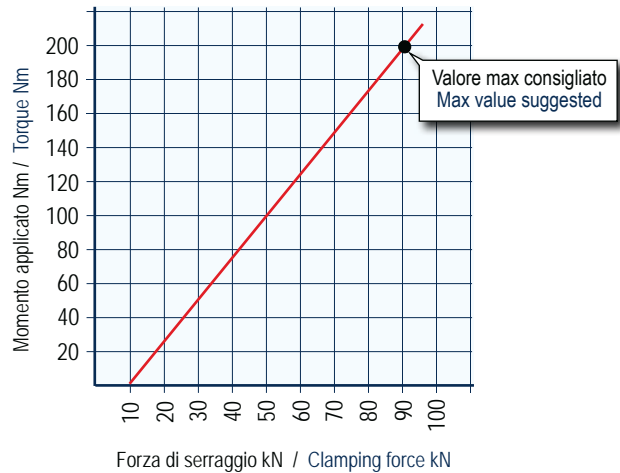

NB: Alcuni fattori, come la lubrificazione, lo staffaggio, gli attriti ed altro, possono modificare i valori indicati fino a  $\pm 10\%$ .  
Per un corretto utilizzo non superare i valori indicati nel grafico

Some factor as lubrication, clamping on the machine table, frictions and more can modify above values within a  $\pm 10\%$  range.  
For optimum operation do not exceed chart values.



Tipo (grandezza) morsa / Vise (type) size	1	2	3	
Apertura massima / Maximum spread	A	100	120	160
	W	75	100	125
	B	32	45	50
	C	95	116	139
	D	214	244	303,5
	E	150	200	240
	kg	9	15	26
Cod.	1.66.71000	1.66.72000	1.66.73000	

**Art. 667**

Morse di precisione con barraseno (0 - 90°)  
Precision sine vises (0 - 90°)

- Superfici rettificate, temperate e lappate
- Ortogonalità e parallelismo: 0,003 mm / 100 mm
- Ideali per operazioni di controllo, rettifica, elettroerosione e fresatura
- All case hardened and hardened HRC 60 steel
- Squareness and parallelism: 0,003 mm / 100 mm
- Ideal for grinding E.D.M. machine and for milling operations also for checking and control

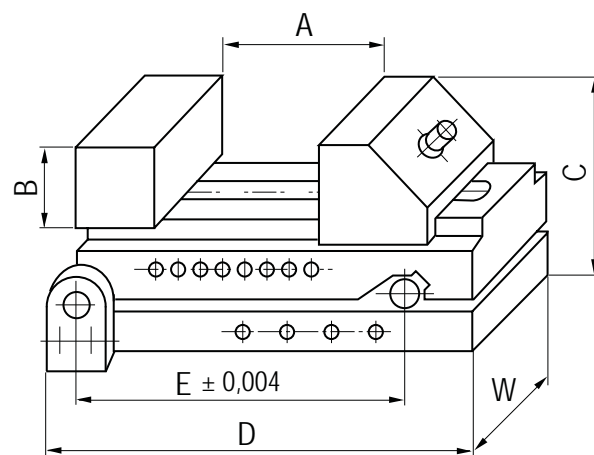

Dotazione standard: 2 chiavi di servizio Art. 376  
Standard equipment: 2 wrenches Art. 376

Tipo (grandezza) morsa / Vise (type) size	1	2	3	
Apertura massima / Maximum spread	A	100	150	214
	W	32	32	36
	B	30	35	40
	C	95	100	110
	D	170	226	300
	kg	4	5	6
Cod.	1.66.81000	1.66.82000	1.66.83000	

**Art. 668**

Morse di precisione in acciaio inox  
Stainless steel precision vises

- Costruita in acciaio inox. Durezza HRC50-55  
Parallelismo e ortogonalità 0,005-0,008. Alta resistenza alla corrosione.  
Ideali per operazioni di controllo e elettroerosione
- Made of high quality stainless steel. Hardness HRC50-55.  
Parallelism and squareness of 0,005-0,008 mm. High corrosion-resistance.  
Best for measurement, inspection, EDM and wire-cutting machining.

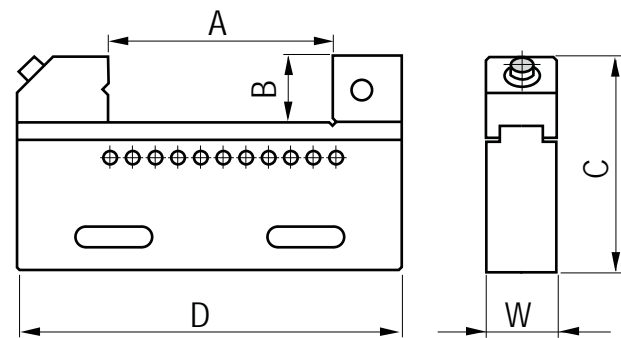
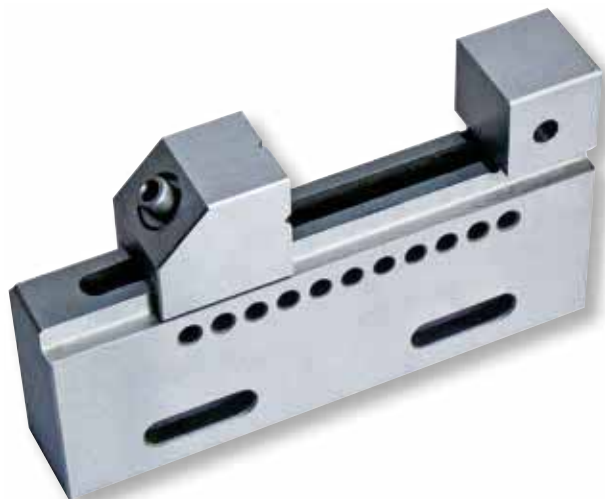

Dotazione standard: 1 chiave di servizio Art. 376  
Standard equipment: 1 wrench Art. 376

Tipo (grandezza) morsa / Vise (type) size		1	2
Apertura massima / Maximum spread	A	130	130
Forza di serraggio / Clamping force	kN	150	300
	W	105	130
	B	40	45
	C	105	110
	D	317	370
	E	130	160
	kg	29,5	42
	Cod.	1.67.11000	1.67.12000

**Art. 671**

Morse pneumatiche / Pneumatic vises

Ingresso aria 3/4" gas - Ø 8 - 7bar  
Air inlet 3/4" gas - Ø 8 - 7bar



Tipo / Type 1



Tipo / Type 2

- Costruita in acciaio di alta qualità, cementato e temprato  
Durezza HRC58-62
- Ortogonalità e parallelismo: 0,02 mm
- Superfici rettificate, temprate e lappate
- Utilizzabili con pressione aria a 6bar (Connessione 1/4" gas)
  
- Made in high-quality alloy steel, case harden HRC58-62
- Squareness and parallelism: 0,02 mm
- Ideal for grinding E.D.M. machine and for milling operations also for checking and control
- Rating air pressure is 6bar (Air inlet - 1/4 " gas)

Dotazione standard: 1 arresto laterale Art. 370  
Raccordo per aria (1/4" gas - Ø8) Art. PN04  
Standard equipment: Workstop Art 370  
Air connection (1/4" gas - Ø8) Art. PN04

